

EXTERIOR SIGNAGE
GUIDELINES

JANUARY 2018



TABLE OF CONTENTS

1.0 OVERVIEW	5
2.0 GRAPHIC STANDARDS	6
3.0 TYPE M - MONUMENT	7
4.0 TYPE B - BUILDING MOUNTED	18
5.0 TYPE S - SPECIALITY SIGNAGE	25



1.0 OVERVIEW

The UAB Exterior Signage Guidelines document establishes the standard for exterior signage on-campus for all facilities. The guidelines are an update and replacement for the Standard Campus Graphics and Signage System for the University of Alabama at Birmingham document prepared previously. The intent of the guidelines is provide direction for signage for new buildings and provide guidance for replacement of existing signage on campus. The review of all exterior signage proposals and implementation of new signage on campus is under the purview of the Office of Planning Design & Construction.

Due to the variation in building types, design characteristics, occupants and naming of facilities, the UAB campus is architecturally diverse. The intention of the guidelines is to provide general guidance for the placement of signage throughout the campus to foster a clear and unified signage

system and reduce visual clutter. The guidelines provide flexibility to address each application while still applying an enterprise wide strategy.

The UAB Signage Guidelines primarily focuses on three types of signage applications, Monument, Building Mounted, Speciality signage.

All new applications will be reviewed on a case-by-case basis to review signage comprehensively to avoid over-signing each building and/or the surrounding grounds.

2.0 GRAPHIC STANDARDS

FONT TYPE

All standard exterior signage shall utilize Helvetica Medium.
In general, all text shall be justified left.
Refer to signage types for uppercase / lowercase direction.

Helvetica medium

Aa Bb Cc Dd Ee Ff Gg Hh Ii Jj Kk
Ll Mm Nn Oo Pp Qq Rr Ss Tt Uu Vv
Ww Xx Yy Zz
0 1 2 3 4 5 6 7 8 9

LOGO

Standard UAB logo is available online at UAB Brand Toolkit.
<https://www.uab.edu/brand/home/downloads/logo>



COLORS & MATERIALS

Colors shown represent UAB's primary exterior sign colors and materials.

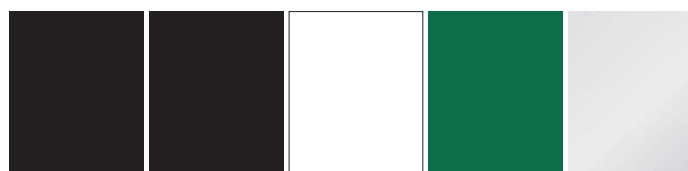

	Black	Dark Bronze	White	UAB Green	Metallic
Pantone	Black 2C	PMS 476c	11-0601	PMS 3425C	-
Paint	SW 6258	SW 6991	SW 7757	SW 6748	Brushed Aluminum

3.0 TYPE M - MONUMENT

There are three standard Building Identification Monuments. All monuments are double sided. While several other options exist currently on campus, future applications would be limited to these standards. Variations to the monument signage within the Medical District are permitted.

Planting materials shall be limited in height so as not to obstruct the signage.

All new buildings shall be required to have a minimum of one Building Identification Monument. This sign type identifies

specific destinations within UAB such as a building name and/or functions within a building. The monument shall be located so as to be visible from the street. For buildings that front a significant open space, such as the Campus Green, a second monument sign shall be located fronting that open space. Type M1 and M2 signs shall be lighted externally.

Secondary Building Identification Monuments (Type M3) shall be used for secondary entrances to facilities, such as a side street or parking lot. Type M3 monuments are also referred to as Flag Signs. Secondary monuments may be used as

primary building signage on smaller buildings or buildings with minimal public interface. Type M3 monuments are generally not lighted.

All monument signage shall use matte white 3M vinyl machine cut lettering with Helvetica Medium text font.



TYPE M1: BUILDING IDENTIFICATION MONUMENT

- A** Logo
 Logo Color: White
 Logo Border: 1.5"
 Logo Size: 5"

- B** Building Name
 Text Justified: Left
 Text Border: Maintain 2" edge
 Text Size (Max./ Min): 7" / 4"

- C** Painted Aluminum Face Panel
 Color: Dark Bronze
 Thickness: (0.090)
 Finish: Matte Clear Coat

- D** Building Address
 Text Justified: Left
 Text Border: Maintain 2" edge
 Text Color: White
 Text Type: Uppercase
 Text Size (Max./ Min): 4" / 2"

- E** Information / Building Occupancy Text
 Text Justified: Left
 Text Border: Maintain 2" edge
 Text Color: White
 Text Size (Max./ Min): 4" / 2"
 Maximum lines of Text: 5

- F** Green Painted Reveal

- G** Concrete Foundation. 4" exposed

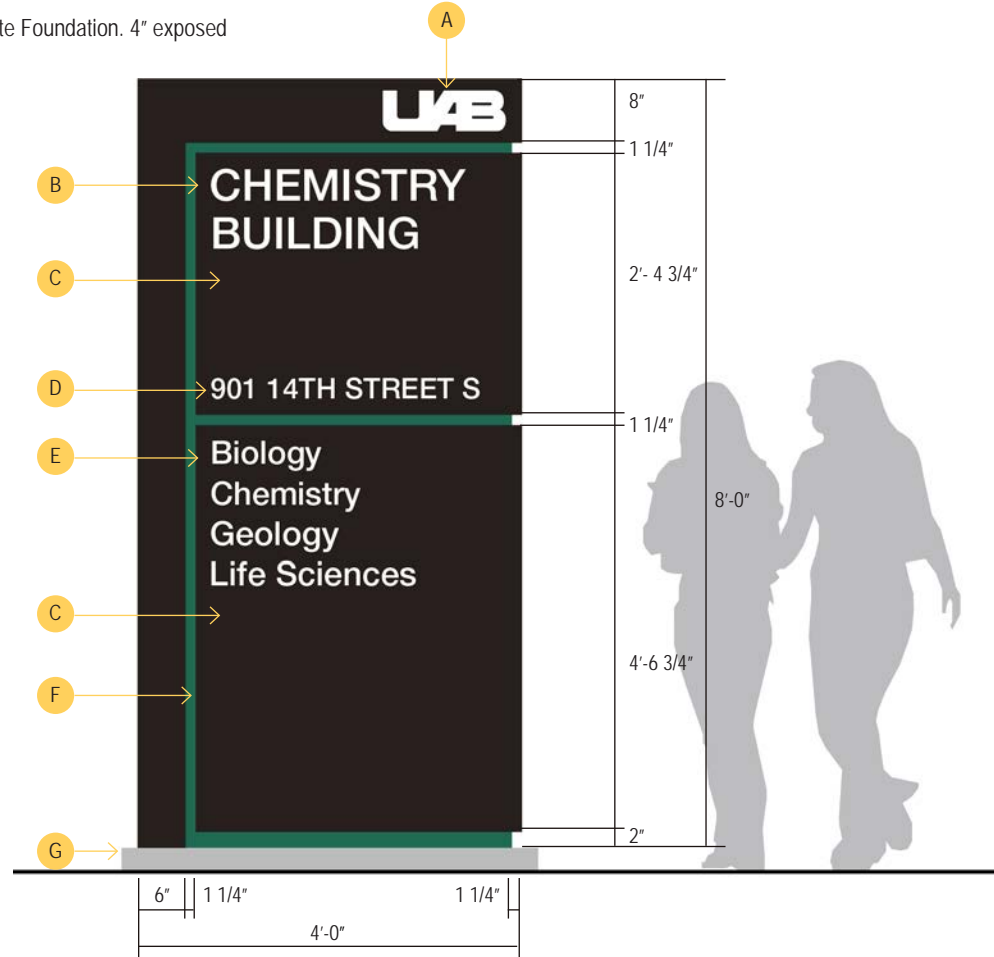

**TYPE M2: BUILDING IDENTIFICATION MONUMENT
(HORIZONTAL)**

- A** Logo
Logo Color: White
Logo Border: 1.5"
Logo Size: 5"
- B** Building Name
Text Justified: Left
Text Border: Maintain 2" edge
Text Style: Uppercase
Text Size (Max./ Min): 7" / 4"
- C** Information / Building Occupancy
Text Justified: Left
Text Border: Maintain 2" edge
Text Style: Lowercase
Text Size (Max./ Min): 4" / 2"
Maximum lines of Text: 3
- D** Building Address
Text Justified: Center
Text Border: Maintain 2" edge
Text Type: Uppercase
Text Size (Max./ Min): 4" / 2"
- E** Green Painted Reveal
- F** Painted Aluminum Face Panel
Color: Dark Bronze
Thickness: (0.090)
Finish: Matte Clear Coat
- G** Concrete foundation. 4" exposed

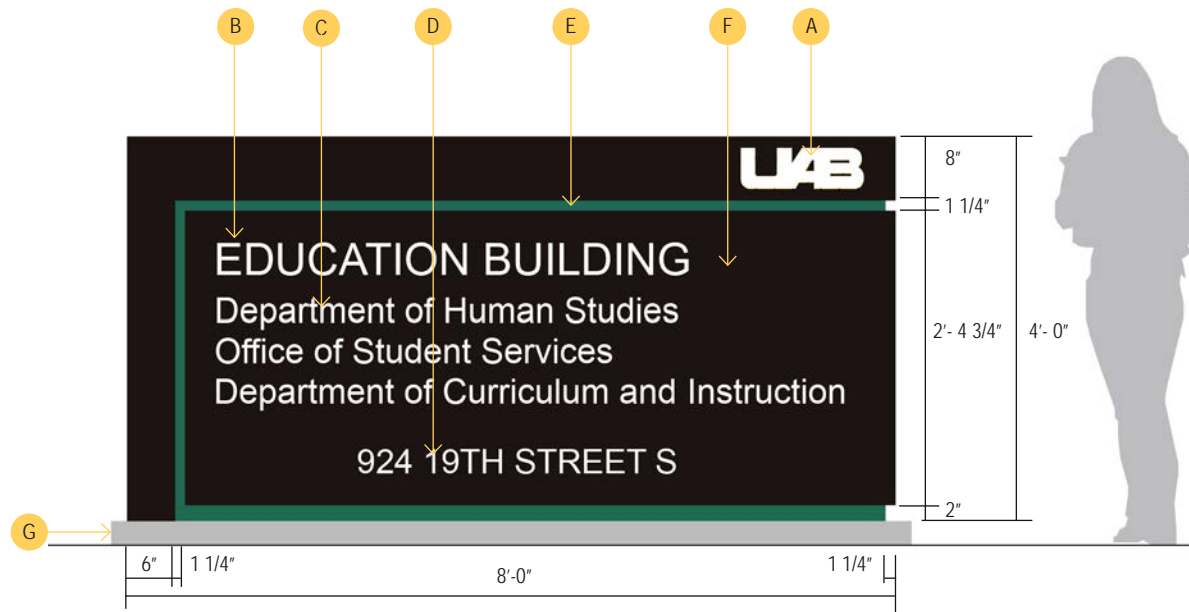

**TYPE M3: SECONDARY BUILDING IDENTIFICATION
MONUMENT (FLAG)**

- A** Logo
 Logo Color: White
 Logo Border: 1.5"
 Logo Size: 3"

- B** Building, Service, or Function Name
 Text Justified: Left
 Text Border: Maintain 2" edge
 Text Color: White
 Text Type: Uppercase
 Text Size (Max./ Min): 4" / 3"

- C** Painted Aluminum Face Panel
 Color: Dark Bronze
 Thickness: (0.090)
 Finish: Matte Clear Coat

- D** Green Painted Reveal

- E** Building Address
 Text Justified: Left
 Text Border: Maintain 2" edge
 Text Color: White
 Text Type: Uppercase
 Text Size (Max./ Min): 2" / 1 1/2"

- F** 4" Square Aluminum Post

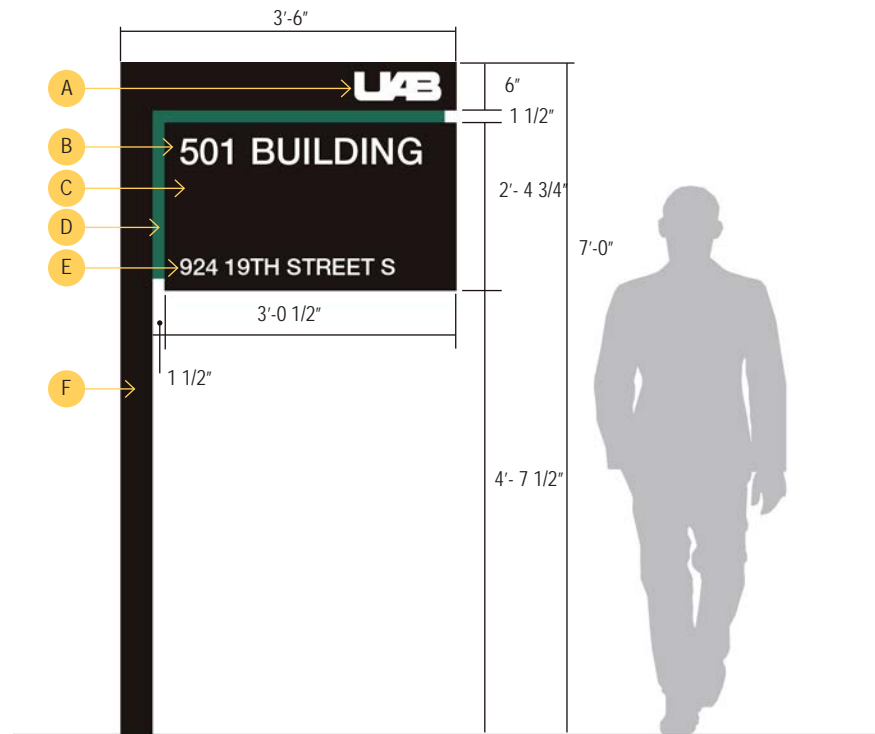

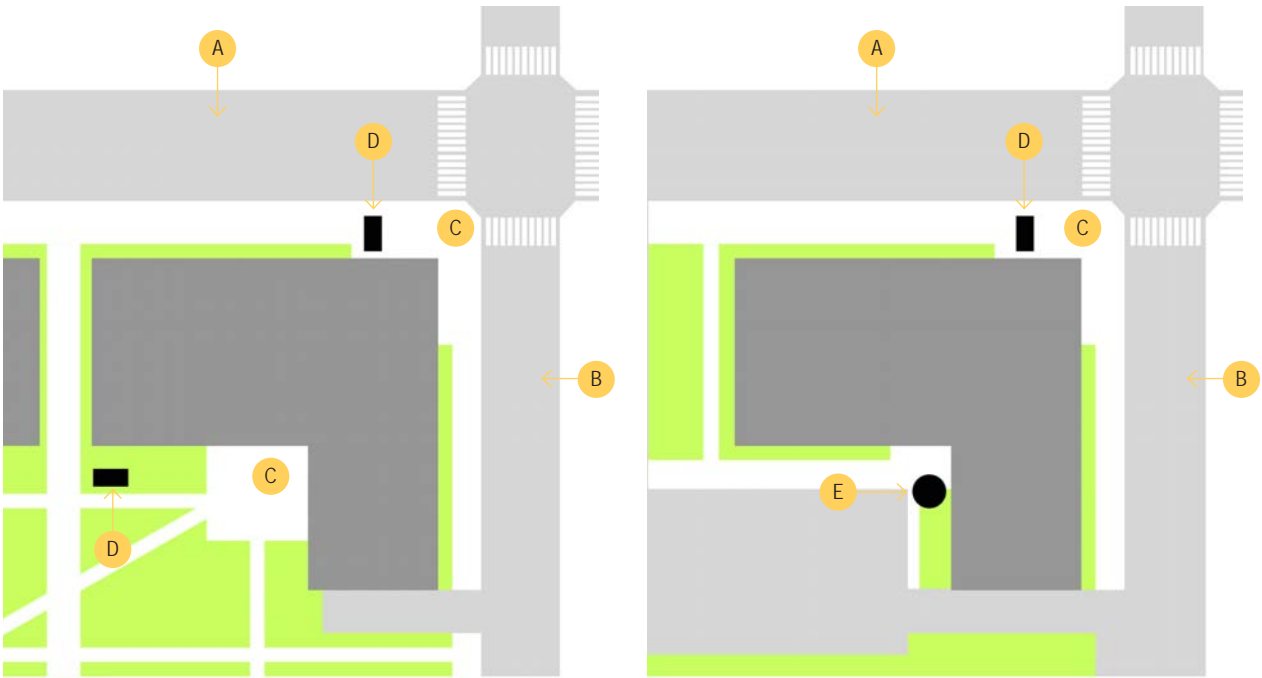

LOCATION PLAN

- A Primary Street
- B Secondary Street
- C Major Pedestrian Entrance
- D Type M1 or M2 Signage
- E Type M3 Signage

TYPE M1 & M2: BUILDING IDENTIFICATION MONUMENT - DETAILS

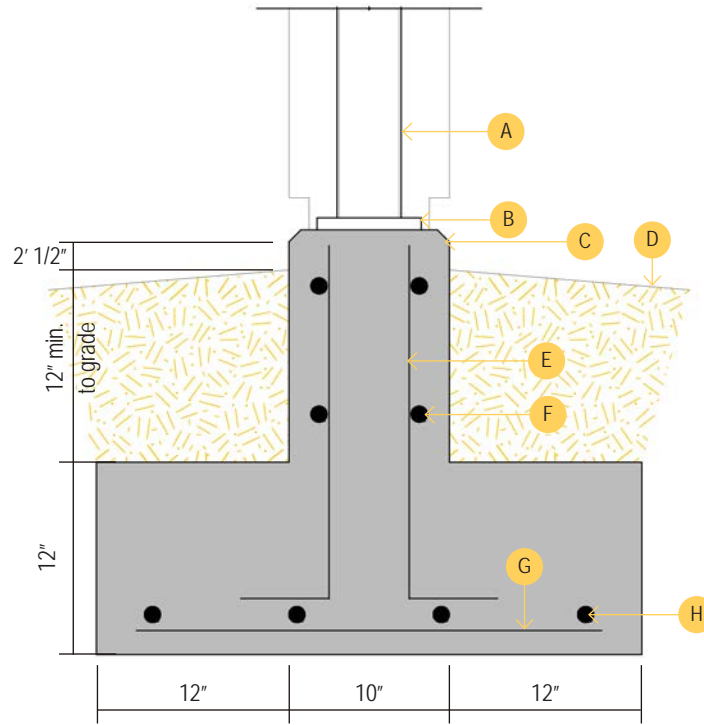
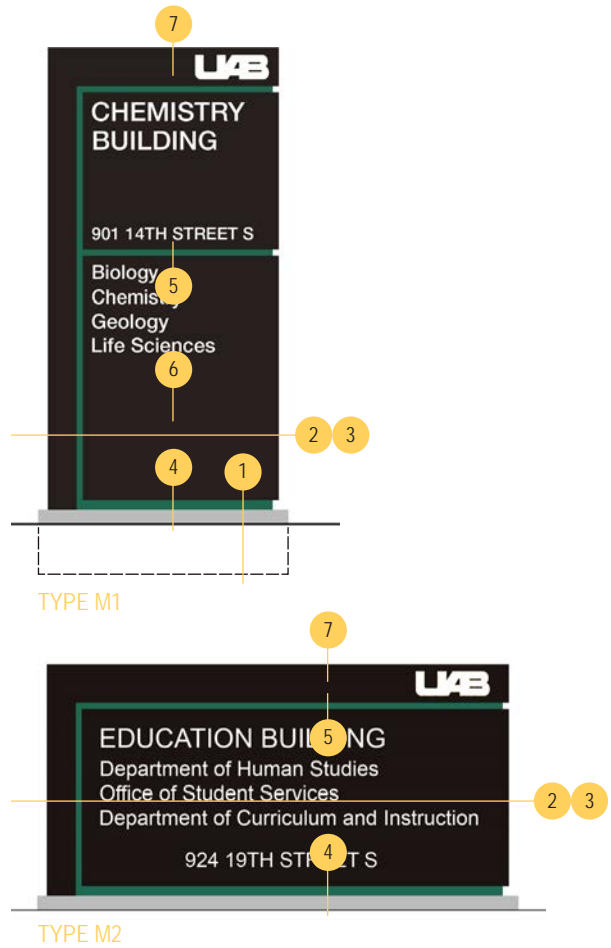

- A Steel Frame
- B (Each Plate) 4 - 1" Round 2'-4" with 4" Hook - A 307 Anchor Bolts
- C 3/4" Chamfer
- D Grade
- E #4's @ 12" o.c. all faces
- F #4 Stirrups - all faces
- G 4 #4's @ 9" o.c.
- H 6 #4's

1 Detail - Footing Section
1" = 1'-0"

TYPE M1 & M2: BUILDING IDENTIFICATION MONUMENT - DETAILS (CON'T.)

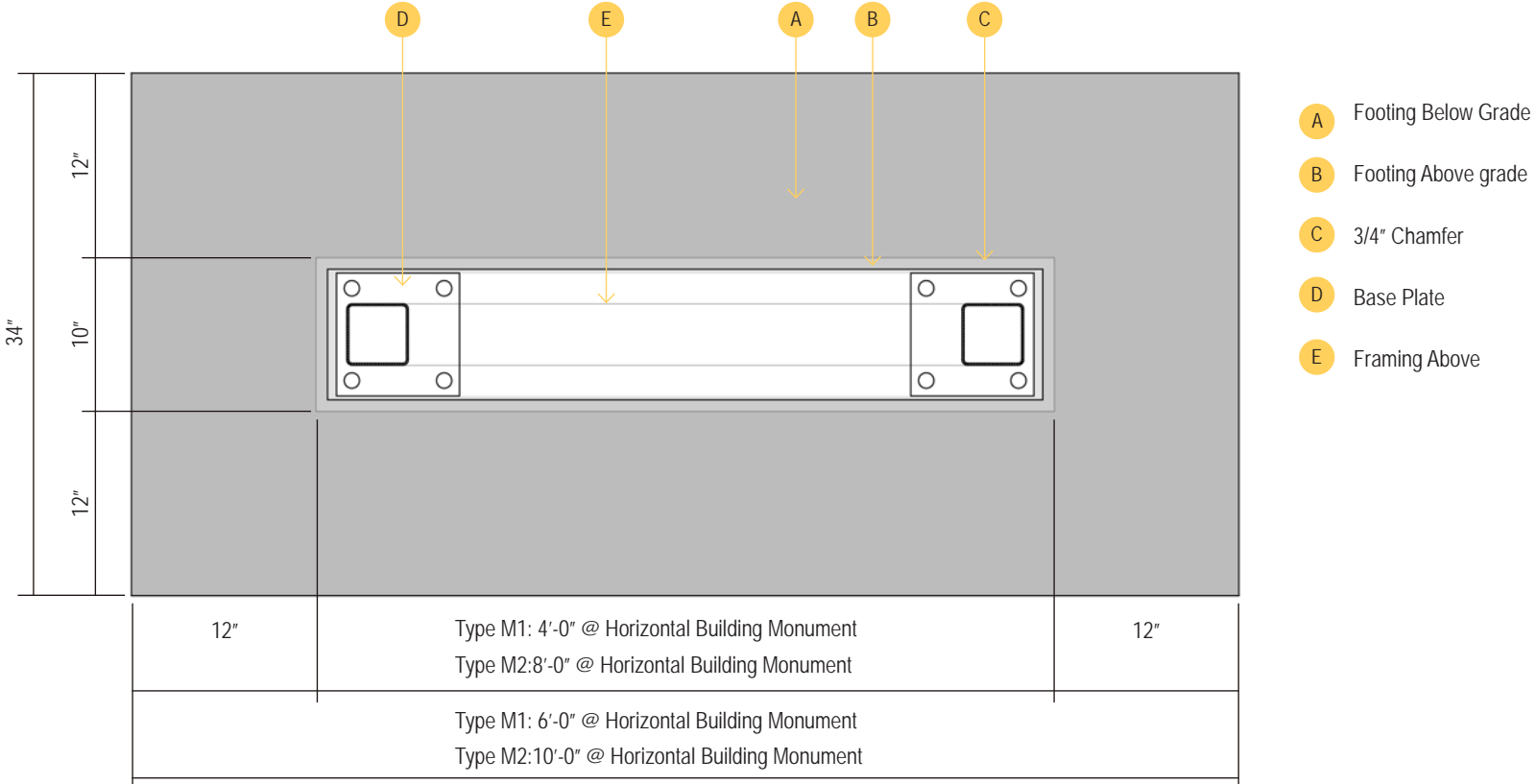

2 Detail - Footing Plan
1" = 1'-0"

TYPE M1 & M2: BUILDING IDENTIFICATION MONUMENT - DETAILS (CON'T.)

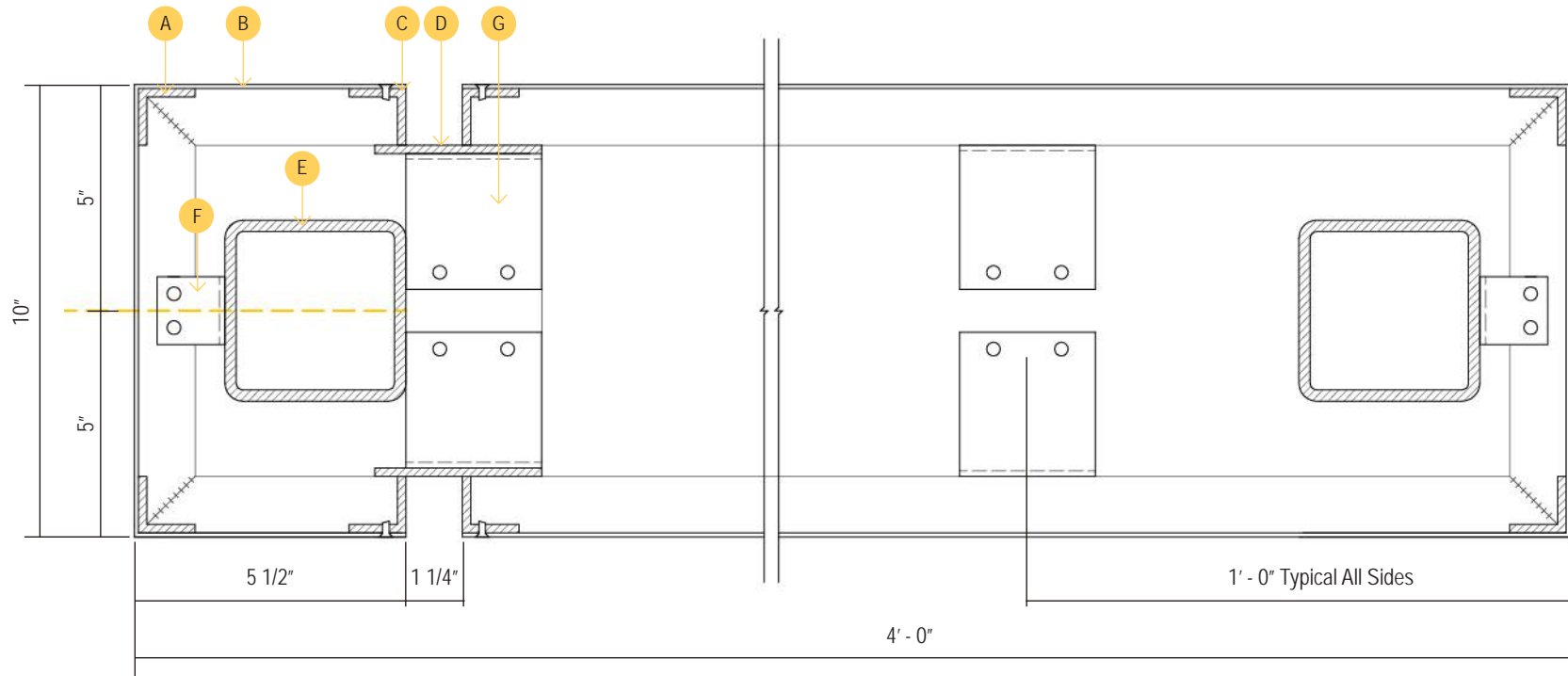

3 Detail - Section
3" = 1'-0"

- A** Continuous Vertical 1 1/4" x 1 1/4" x 3/16" Aluminum Angle
 - B** Aluminum Face Panel
 - C** 1 1/4" x 1 1/4" x 3/16" Aluminum Angle
 - D** 5" x 3/16" Aluminum Flat
- E** 4" x 4" x 1/4" Square Steel Tube Frame
 - F** 1 1/2 x 1 1/2" x 1/8" x 2" Long Aluminum Clip Angle
 - G** 3" x 1 1/2" x 1/8" x 4" Long Aluminum Clip Angle

TYPE M1 & M2: BUILDING IDENTIFICATION MONUMENT - DETAILS (CON'T.)

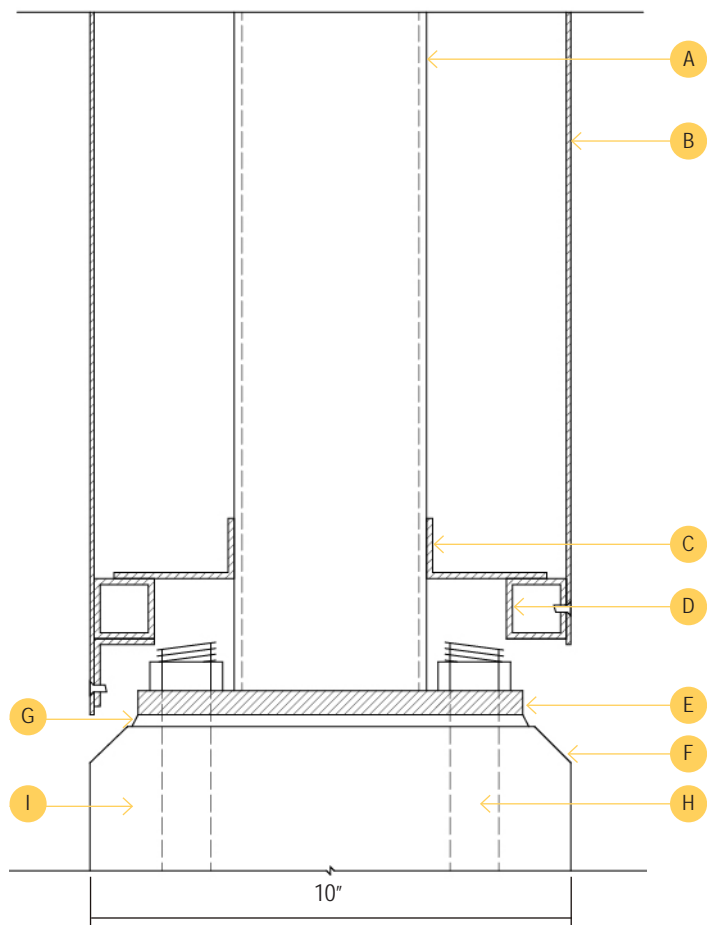

- A Steel Frame
- B Aluminum Face Panel
- C 2 1/2" x 2" x 1/8" x 4" Long Aluminum Angle
- D Continuous 1 1/4" x 1 1/4" x 1/8" Square Aluminum Tube
- E Steel Base Plate
- F 3/4" Chamfer
- G Non-Ferrous, Non-Shrink Grout
- H Anchor Bolt
- I Concrete Footing

4 Detail - Base Reveal
3" = 1'-0"

TYPE M1 & M2: BUILDING IDENTIFICATION MONUMENT - DETAILS (CON'T)

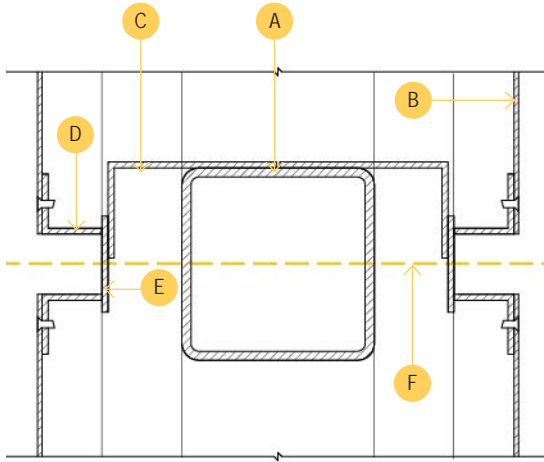

5 Detail - Typical Horizontal Reveal
3" = 1'-0"

- A Steel Frame
- B 0.090 Aluminum Face Panel
- C 3 1/2" x 2" x 1/8" x 4" Long Alum. Clip Angle
- D 1 1/4" x 1 1/4" x 1/8" Alum. Angle
- E 2 1/2" x 3/16" Alum. Flat
- F Note: Vertical Relationship of Steel Framing and Reveal Varies, Refer to Steel Frame Elevations and Sign Elevations. Adjust Clip Accordingly.

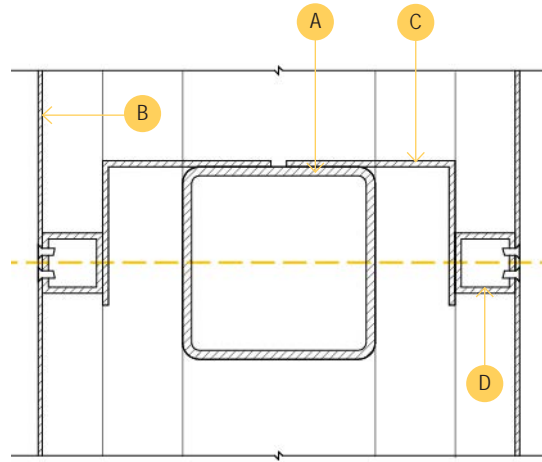

6 Detail - Panel Joint
3" = 1'-0"

- A Steel Frame
- B 0.090 Aluminum Face Panel
- C 3 1/2" x 2" x 1/8" x 4" Long Alum. Clip Angle
- D 1 1/4" x 1 1/4" x 1/8" Alum. Tube

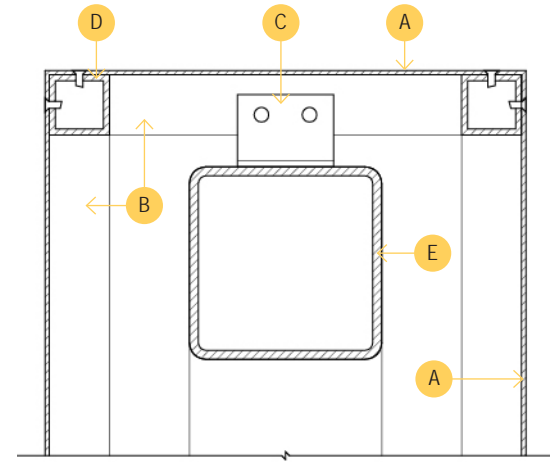

7 Detail - Top
3" = 1'-0"

- A 0.090 Aluminum Face Panel
- B 1 1/4" x 1 1/4" x 1/8" Alum. Tube @ 2'-0" o.c.
- C 3 1/2" x 2" x 1/8" x 4" Alum. Clip Angle Each Member
- D 1 1/4" x 1 1/4" x 1/8" Alum. Tube
- E Steel Frame

TYPE M3: SECONDARY BUILDING IDENTIFICATION MONUMENT (FLAG)

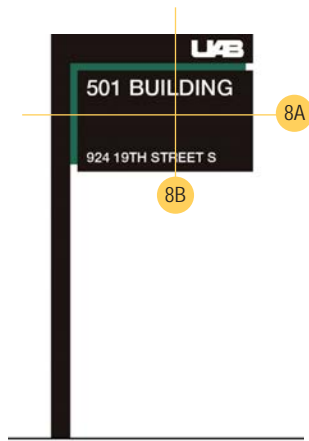

- A 4" x 0.090" Aluminum Continuous
- B 4" x 6" x 3/16" Square Aluminum Tube
- C 4" x 4" x 1/4" Square Aluminum Tube
- D 1 1/2" x 1 1/2" x 3/16" Square Aluminum Tube
- E 2" x 4" x 3/16" Aluminum Channel Frame with Corners
- F Mitered and Welded
- G Aluminum Face Panel Attached to Channel
- H 4" x 4" x 1/4" Square Aluminum Tube Beyond

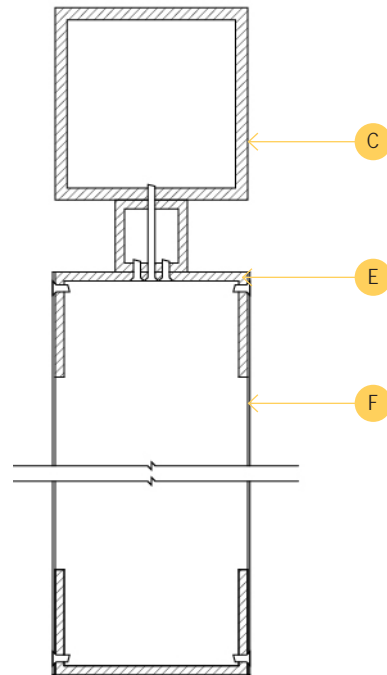

8A Detail - Typical Sections
3" = 1'-0"

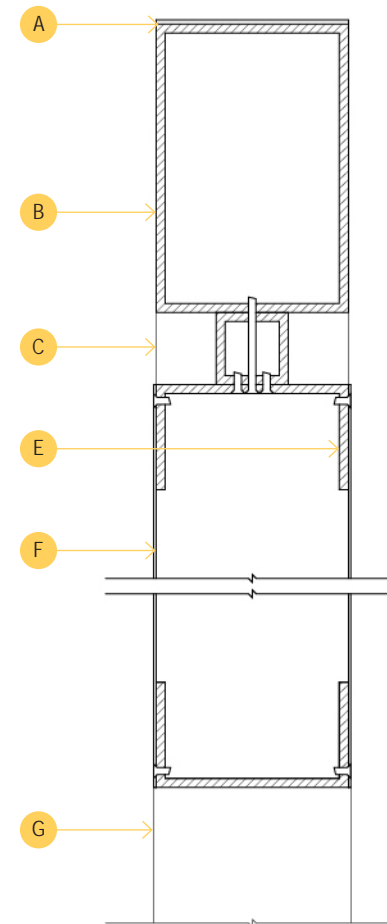

8B Detail - Typical Sections
3" = 1'-0"

4.0 TYPE B - BUILDING MOUNTED

There are three types of Building Mounted Signage at UAB. All new buildings are required to have Building Mounted Signage. Types include:

Type B1: Building Identification Signage

Type B2: Pedestrian Level Signage

Type B3: Primary Address Plaque

TYPE B1: BUILDING IDENTIFICATION SIGNAGE

It is the intent of these guidelines that each building at UAB will eventually be identified by Building Identification Signage. Building Identification Signage shall be placed to front the primary street. In cases of buildings fronting multiple streets or open spaces, additional signage is recommended. Building Identification Signage shall be located as close to the top of the building as possible. Location and placement shall be informed by the building's architectural elements. There are three general types of building names:

- Buildings Named for Honoree
- Buildings with College or School Naming
- Buildings with Administrative Naming

In cases where the building has an honoree name, the honoree name shall be listed before the name of the department and or/ occupants within the building. Building Identification Signage shall be limited to the buildings honoree name and/or primary departmental occupant.

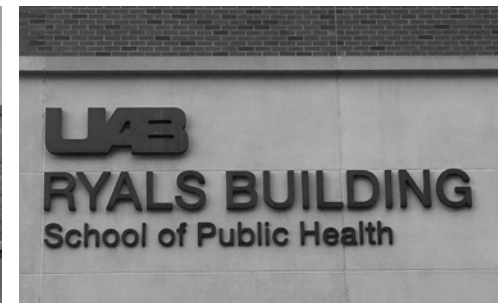

TYPE B1: BUILDING IDENTIFICATION SIGNAGE

Location: Dependent on Building

Size: Dependent on Location

Logo Color: UAB Green

Text: Left Justified

Text Type: Uppercase

Text Color:

- Dark Building Material: Brushed Aluminum
- Light Building Material: Black

Text Sizing:

- Building Name: 80% of Logo Height
- Secondary building name: 60% of Logo Height

Text Thickness: 2" Deep, Non-illuminated

Minimum Text Height: 8"

Naming:

- First Line: Building Name
- Second Line: Secondary Building Name (if applicable)

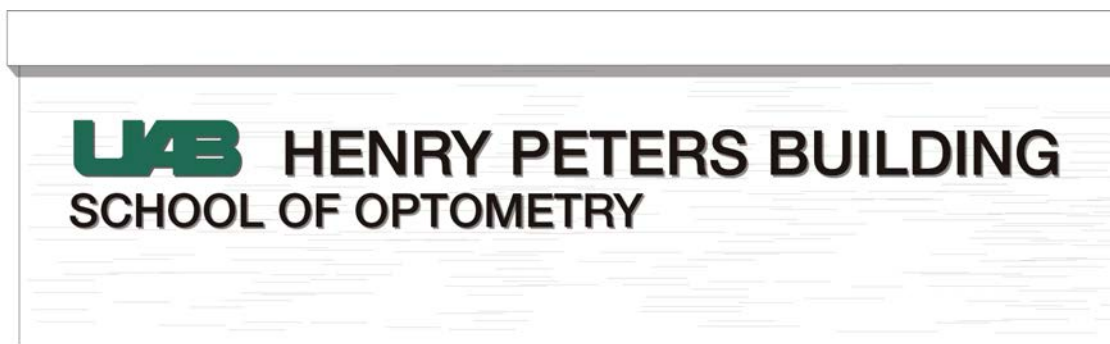

Preferred



Alternate (stacked)

TYPE B2: PEDESTRIAN LEVEL SIGNAGE

Pedestrian Level Signage provides wayfinding at a pedestrian level. Types include Wall Mounted or Glass Located Signage. Wall Mounted Signage shall indicate the Building Name, Department and/or Administrative Naming, and building address. Glass Located Signage shall include Building Name and/or Department. Glass Located Signage may include additional information pertinent to the building user, such as hours of operation.

Pedestrian Level Signage shall be located at all primary building entrances and secondary entrances as deemed necessary. Buildings may incorporate both types of Wall Mounted and/or Glass Located Signage. Each application shall be reviewed with the Office of Public Relations and Marketing for compliance.



Type B1: Wall Mounted Identification (Large)

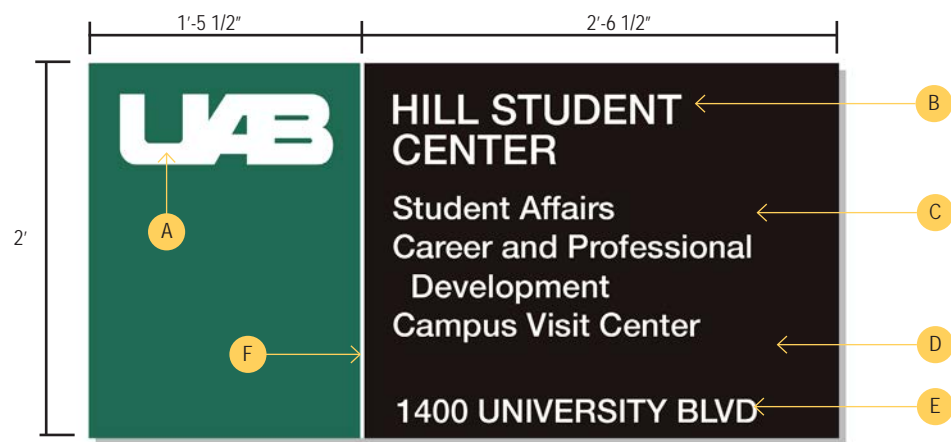

TYPE B2-L: WALL MOUNTED SIGNAGE (LARGE)

- A** Logo
 Logo Color: White
 Logo Border: 2"
 Logo Height: 4.5"
- B** Building Name
 Text Justified: Left
 Text Color: White
 Text Border: Maintain 2" edge
 Text Size: 1.8"
 Maximum Lines: 2
- C** Information / Building Occupancy Text
 Text Justified: Left
 Text Border: Maintain 2" edge
 Text Color: White
 Text Size (Max./ Min): 1.5" / 1.2"
 Maximum Lines of Text: 4
- D** Painted Aluminum Face Panel
 Color: Dark Bronze / UAB Green
 Thickness: (0.090)
 Finish: Matte Clear Coat
- E** Building Address
 Text Justified: Left
 Text Border: Maintain 2" edge
 Text Color: White
 Text Type: Uppercase
 Text Size (Max.): 1.5"
- F** Trim
 Width: 0.25"
 Color: White



TYPE B2-S: WALL MOUNTED SIGNAGE (SMALL)

- A** Logo
 Logo Color: White
 Logo Border: 1.5"
 Logo Height: 2.5"
- B** Building Name
 Text Justified: Left
 Text Color: White
 Text Border: Maintain 1.5" edge
 Text Size: 2"
 Maximum Lines: 2
- C** Information / Building Occupancy Text
 Text Justified: Left
 Text Border: Maintain 1.75" edge (Left),
 1.5" edge (Right)
 Text Color: White
 Text Size (Max./ Min): 1.5" / 1.2"
 Maximum Lines of Text: 4
- D** Painted Aluminum Face Panel
 Color: Dark Bronze / UAB Green
 Thickness: (0.090)
 Finish: Matte Clear Coat
- E** Building Address
 Text Justified: Left
 Text Border: Maintain 1.5" edge (Left to Right), 1" edge
 (Bottom)
 Text Color: White
 Text Type: Uppercase
 Text Size (Max.): 1.5"
- F** Trim
 Width: 0.25"
 Color: White



TYPE B2-G: GLASS LOCATED IDENTIFICATION

- A** Logo
 Logo Color: UAB Green
 Logo Height: Varies

- B** Unit Wordmark - Primary
 Text Color: White
 Text Height: Varies
 Text Justified: Left
 Text Style: Uppercase
 *Primary Wordmark should not exceed height of Logo

- C** Unit Wordmark - Tertiary (Optional)
 Text Color: White
 Text Height: Varies
 Text Justified: Left
 Text Style: Lowercase

TYPE B3: PRIMARY ADDRESS PLAQUE

Each building is required to have an Address Plaque. The plaque shall be located at the building's primary pedestrian entrance. Mounted directly to the building. This plaque contains the building street number only.

Plaque to be 5/8" thick, cast aluminum

Buildings fronting multiple streets may require additional plaques.

- A** Raised Numbers and Border
Color: Silvertone or Bronze (Color informed by building materials)
Address Text: 8 inches
- B** Background and return of letters
Color: Black (Paint)

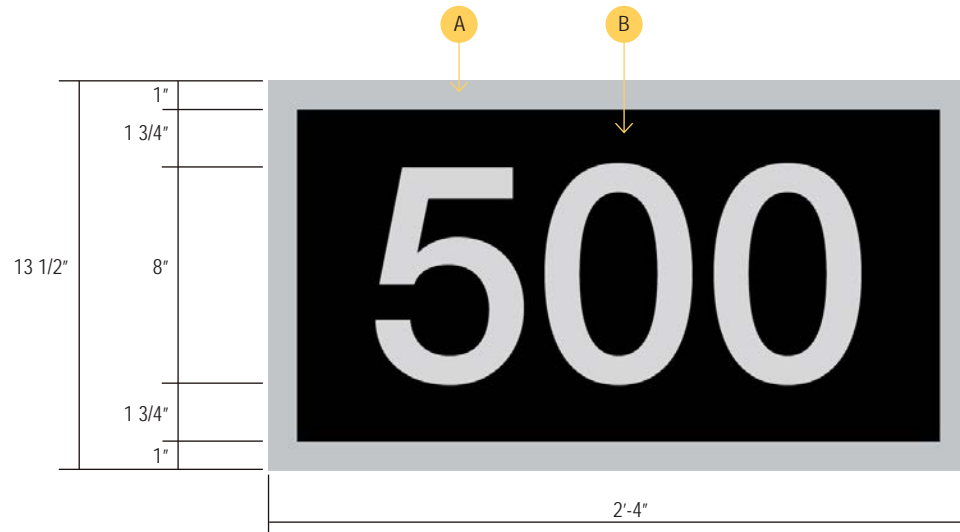

5.0 TYPE C - SPECIALITY SIGNAGE



There is an institutional desire to recognize significant donors and user groups within a building and/or special initiatives on-campus. Each case of specialty signage shall be reviewed on a case-by-case basis for need, appropriateness and location. While being respectful of special initiatives, over-signing a building can be detrimental to both the appearance of the building as well as negatively affecting the visual clarity of the campus.

Specialty signage on-campus can provide a needed wayfinding element for pedestrian and vehicular movement on-campus. In many cases, entrances to buildings on campus are not easily visible from the public right-of-way. However, additional signage shall be limited to directional signage and will need to show that it does not detract from the visual clarity of the space.

Free-standing signage shall meet the color and material requirements of the Monument Standards.

Specialty signage that is pole mounted, such as directional or parking lot signage located on UAB property, shall meet the Pole Mounted Signage (Type S1) requirements.

UAB reserves the right to remove any permanent or temporary signage within the campus without notice. Temporary advertising signage is strictly prohibited.



TYPE S1: POLE MOUNTED SIGNAGE

- A** 14 Gauge 2" Square Tube Pipe Sanded, Primed and Painted with Rustproof Gloss Black Paint (Two Coats)
- B** 2" Post Cap (No. 807, Lawler Foundary or Equivalent), Sanded, Primed, and Painted with Rustproof Gloss Black Paint (Two Coats)
- C** Signs shall be standard signs (flat panel) 0.080 aluminum or 14 gauge steel flat panel. Signs shall be mounted on posts with galvanized fasteners. All striping, legends, markings and signage shall conform to ALDOT special and standard highway drawings and specifications, latest edition
- D** Color: Black
Trim: 1/4" White trim
Logo: White
Text: White
Text Type: Uppercase
Corners: 1/2" Rounded
- E** Color: Black or UAB Green
Trim: 1/4" white trim
Logo: White
Text: White
Text Type: Uppercase
Corners: Square

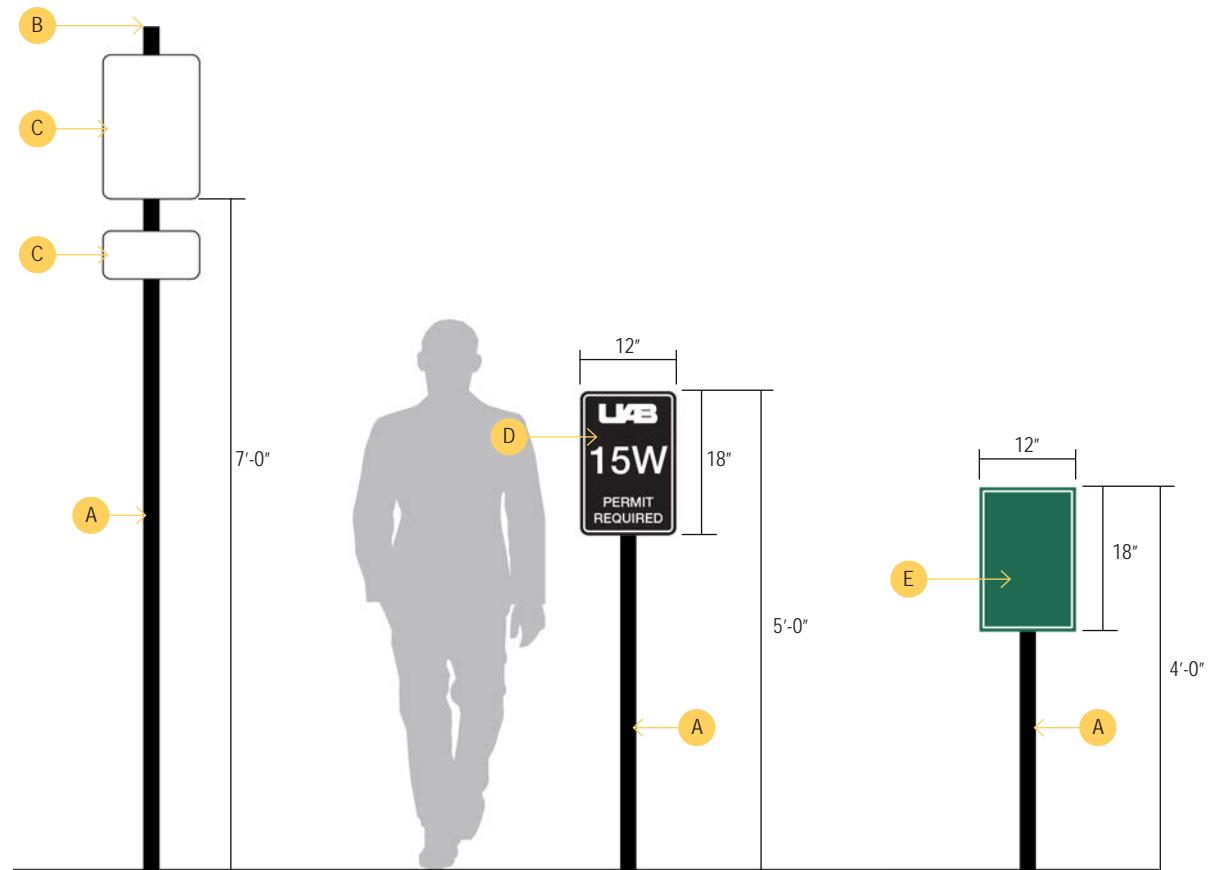

Type S1: Parking Lot Directional

Type S2: Parking Lot Identification

Type S3: Pedestrian Directional

