

**Mass spectrometry of
proteins, peptides and other
analytes: principles and
principal methods**

Matt Renfrow

January 9, 2007

Objectives of the Lecture

1. **Make ions**
2. **Separate/Analyze/Detect ions**
3. **What is mass resolution and mass accuracy?**

What does a mass spectrometer do?

1. It measures mass better than any other technique.
2. It can give information about chemical structures.

What are mass measurements good for?

To identify, verify, and quantitate: metabolites, recombinant proteins, proteins isolated from natural sources, oligonucleotides, drug candidates, peptides, synthetic organic chemicals, polymers

Applications of Mass Spectrometry

Pharmaceutical analysis

- Bioavailability studies
- Drug metabolism studies, pharmacokinetics
- Characterization of potential drugs
- Drug degradation product analysis
- Screening of drug candidates
- Identifying drug targets

Biomolecule characterization

- Proteins and peptides
- Oligonucleotides

Environmental analysis

- Pesticides on foods
- Soil and groundwater contamination

Forensic analysis/clinical

MS of Proteins and Peptides

1D gel



2D gel

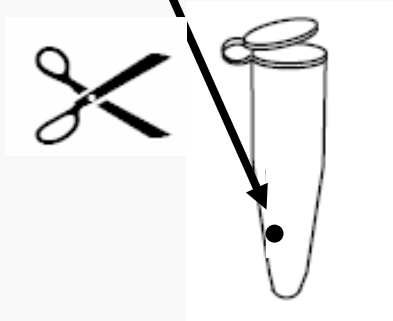
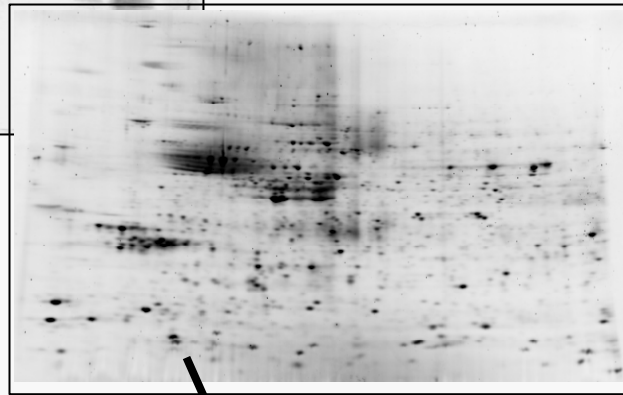

**Protein
mixture
or
Complex
mixture**

Put it in your machine and tell me the RIGHT answer

1D gel

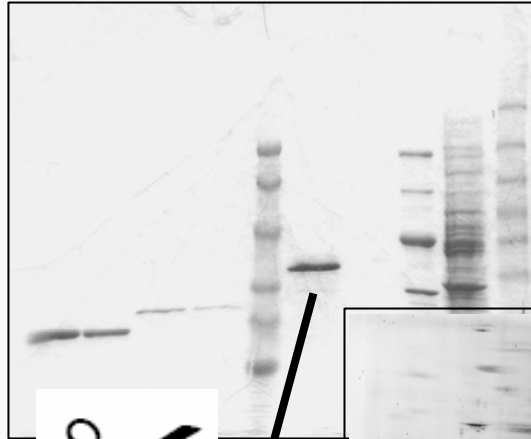

2D gel

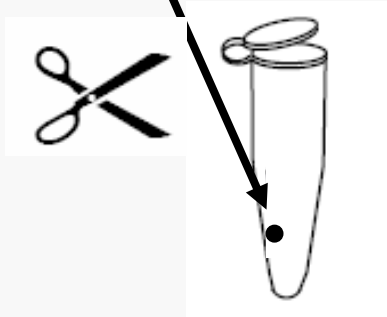
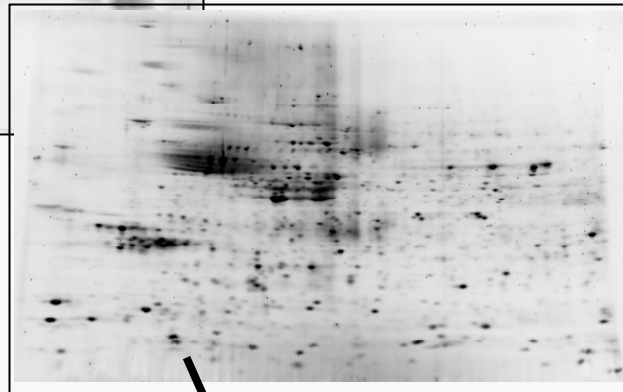

**Protein mixture
or
Complex mixture**



Put it in

- We need ions (+ or -)
- In the gas phase

Your machine

- ToF, ToF ToF
- Quadrupole, Ion trap
- FT-ICR, Orbitrap (high resolution)
- Hybrids

Tell me the RIGHT answer

- How right is it?

mass resolution and accuracy

How does a mass spectrometer work?

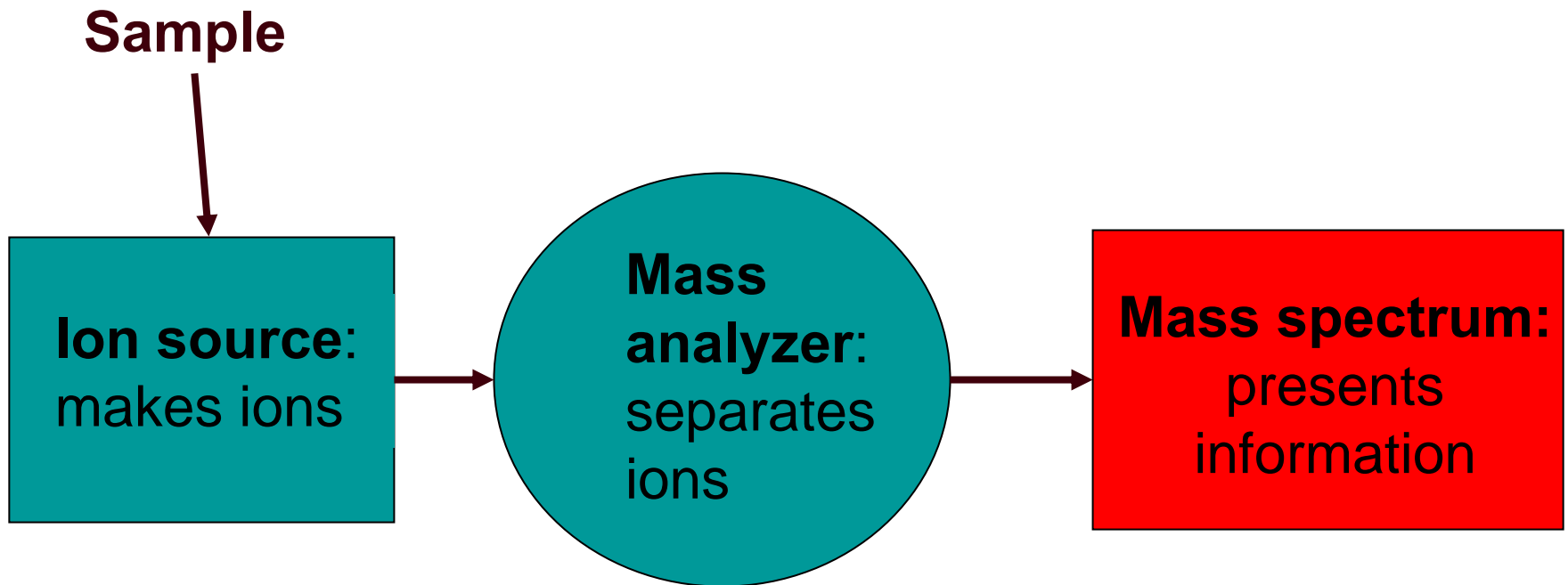

Mass Spectrometer Block Diagram

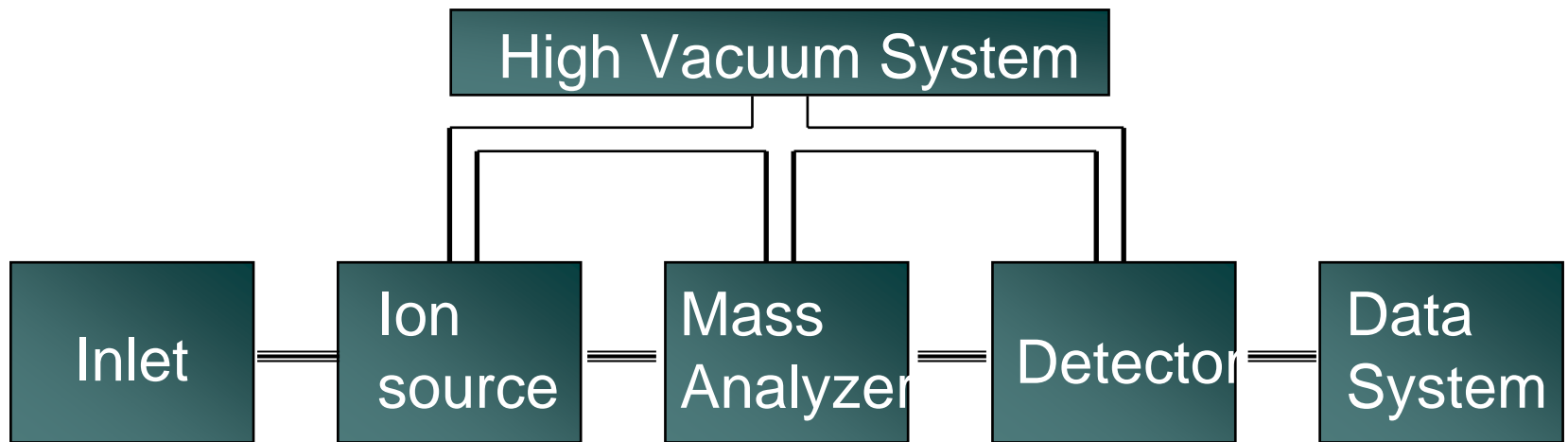

Mass Spectrometer Block Diagram

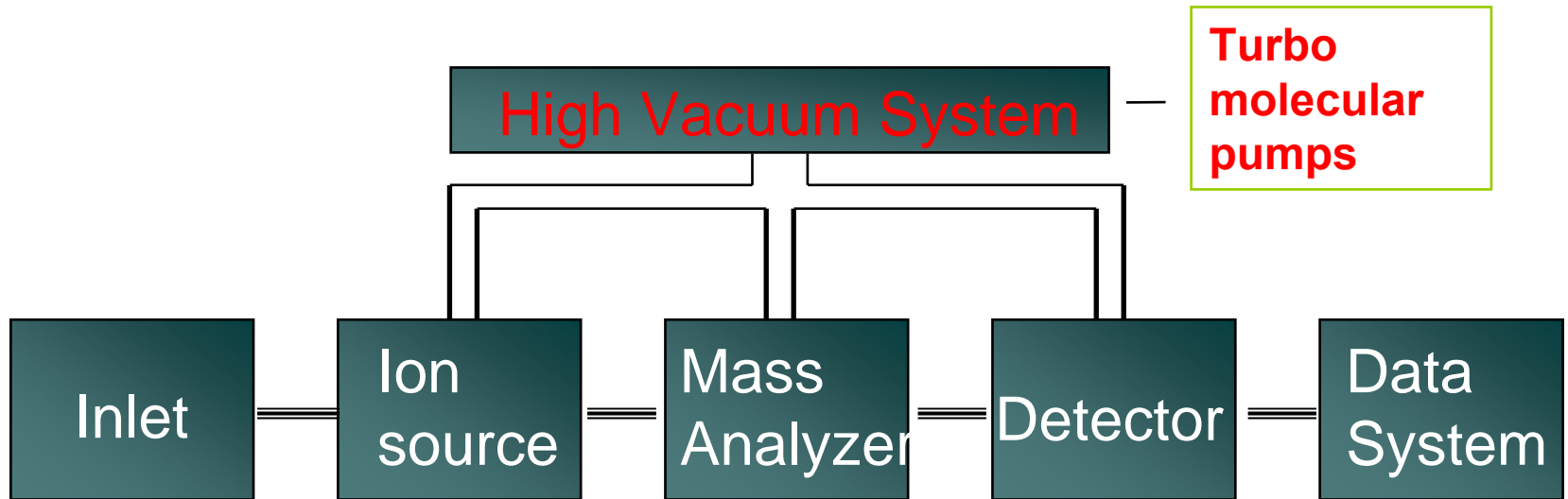

Sample Introduction

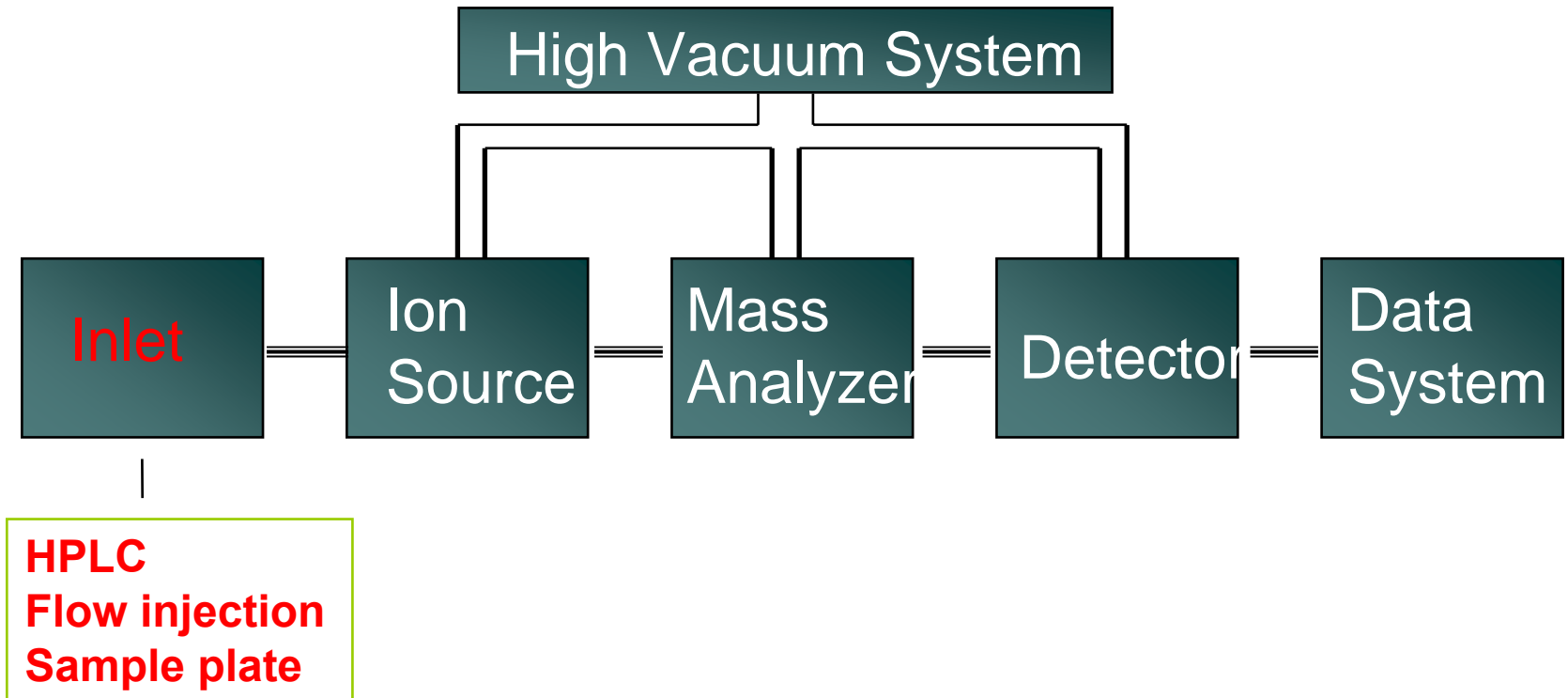

Ion Source

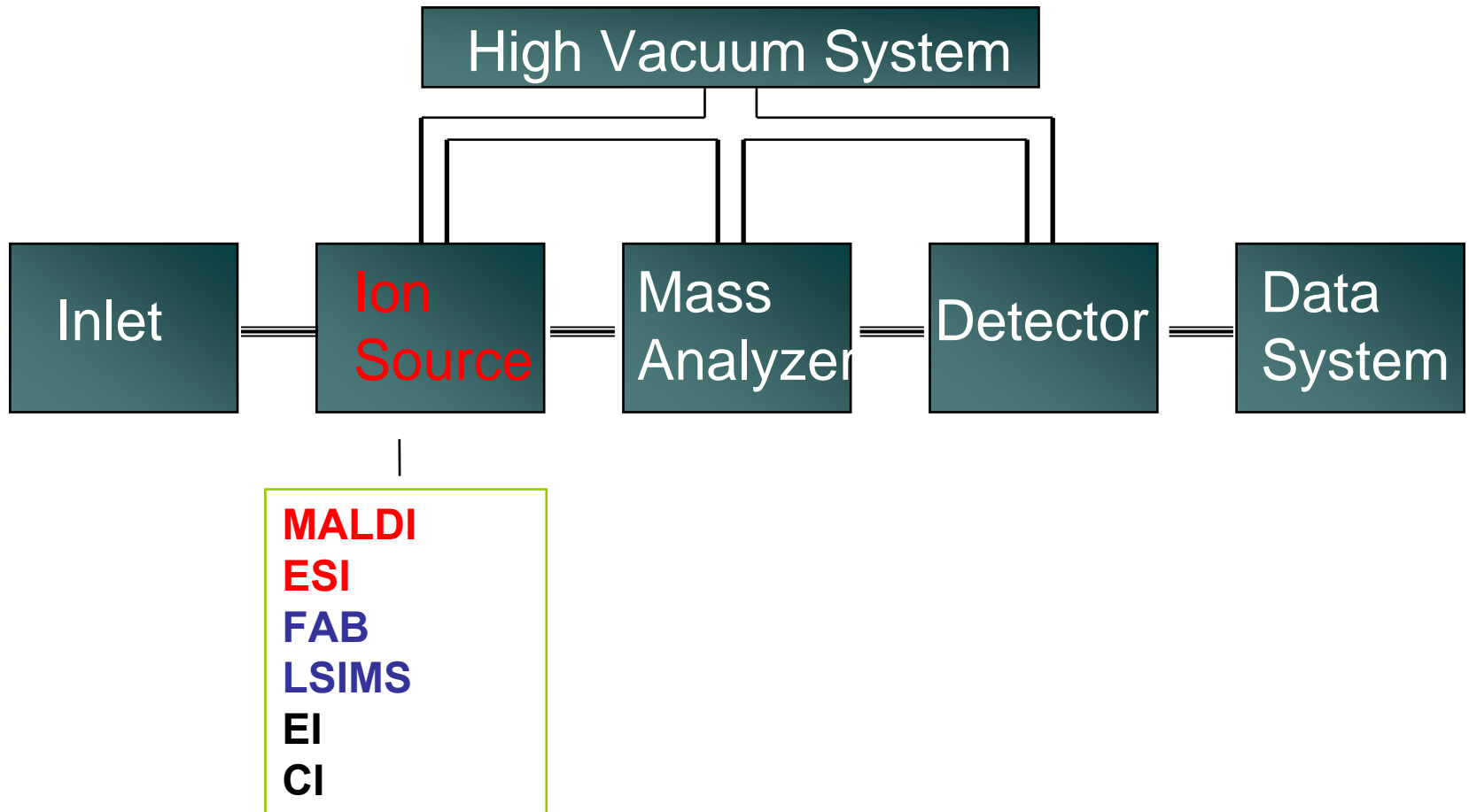

Nobel Prize in Chemistry- 2002

For getting proteins and peptides into the gas phase

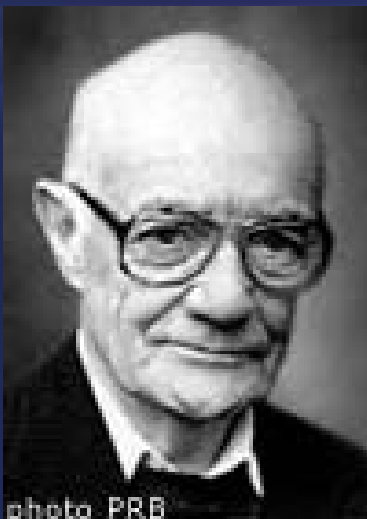

John Fenn



Koichi Tanaka

"for the development of methods for identification and structure analyses of biological macromolecules"
and
"for their development of soft desorption ionisation methods for mass spectrometric analyses of biological macromolecules"

Ion Sources make ions from sample molecules

(Ions are easier to detect than neutral molecules.)

Electrospray ionization:

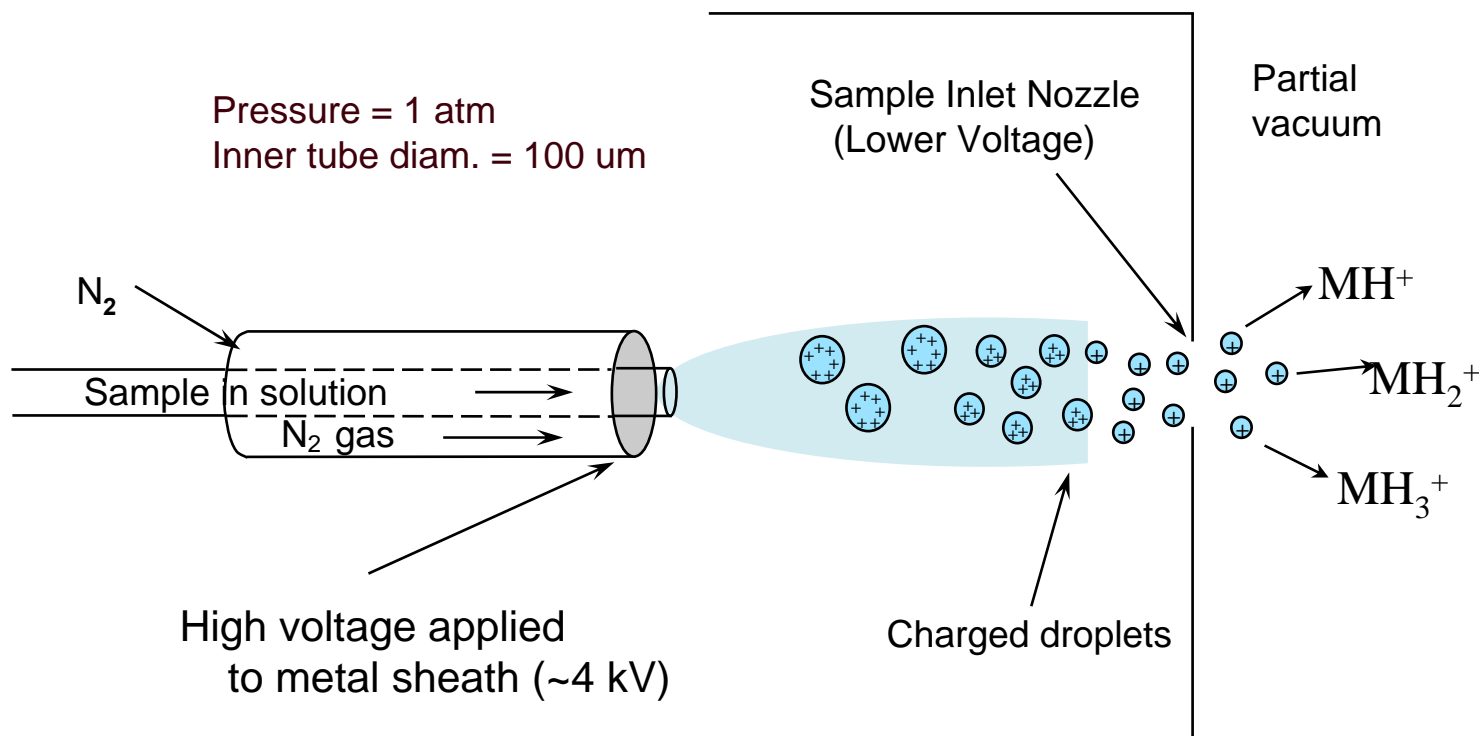

Electrospray Ionization (ESI)

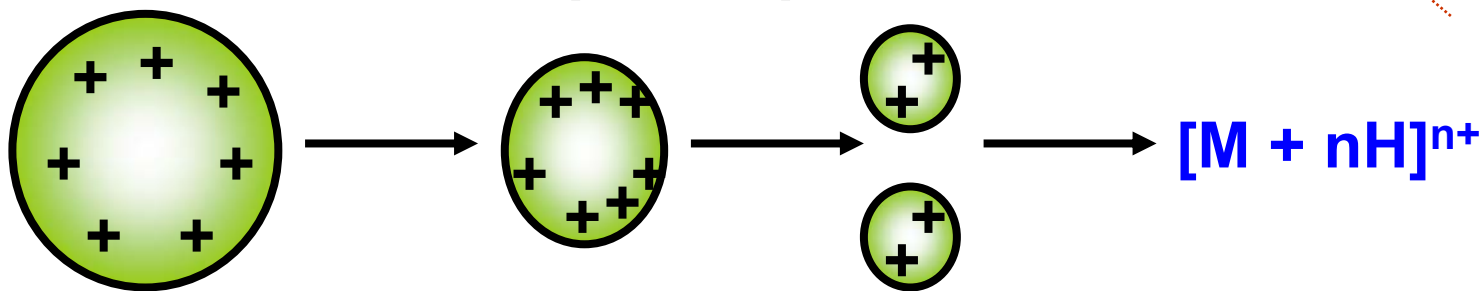
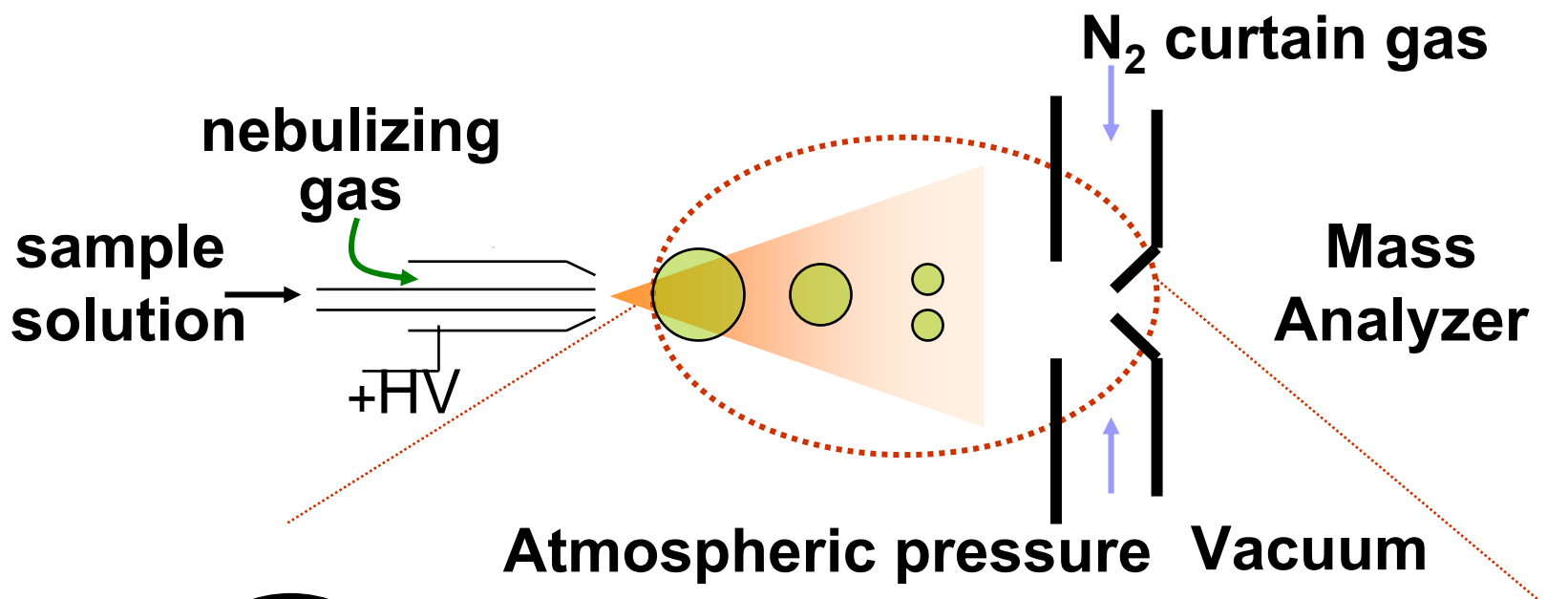

1. Solvent evaporation
2. Coulombic repulsion

Electrospray Ionization (ESI)

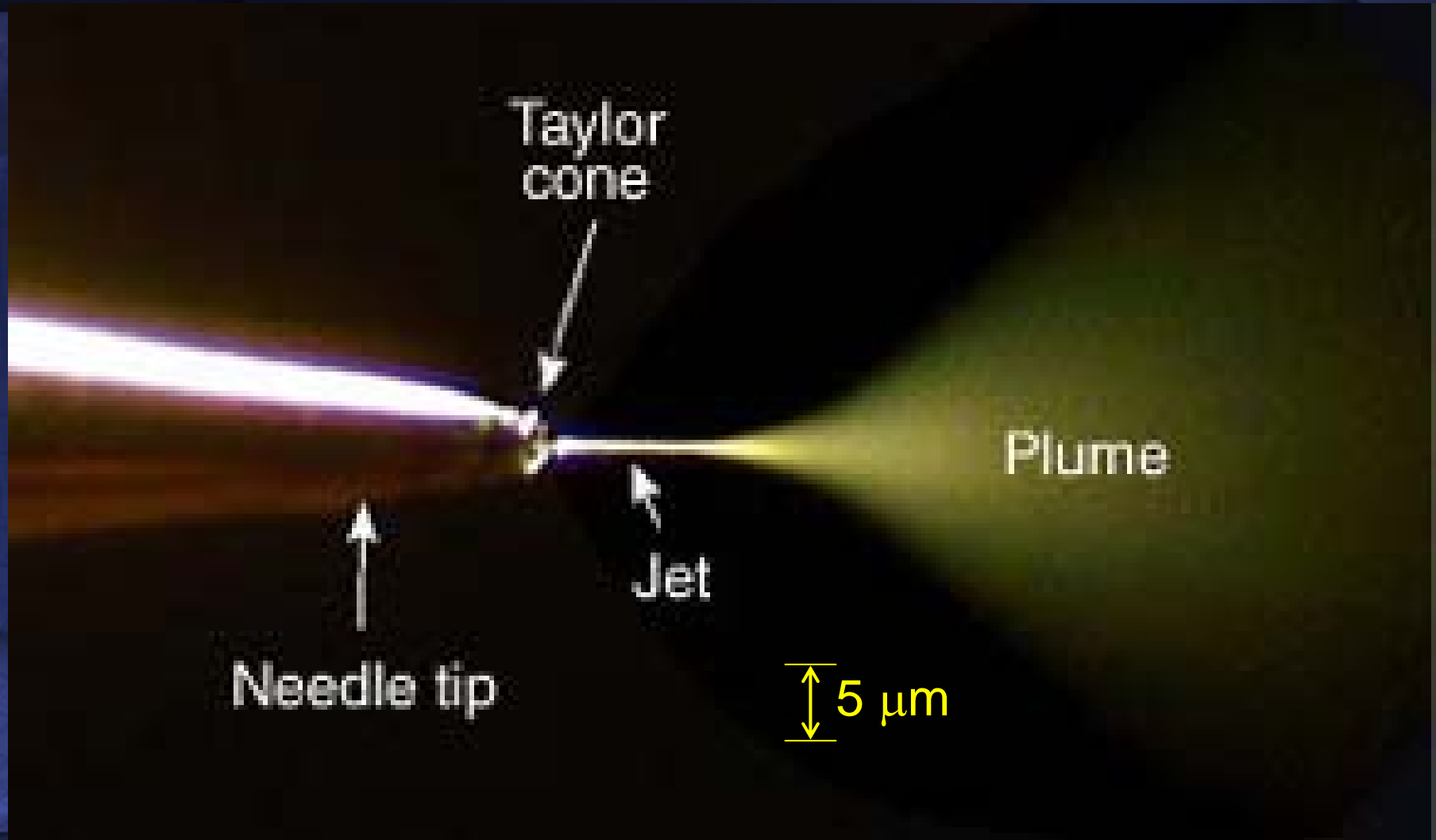

Electrospray Ionization (ESI) Process (Positive Mode)

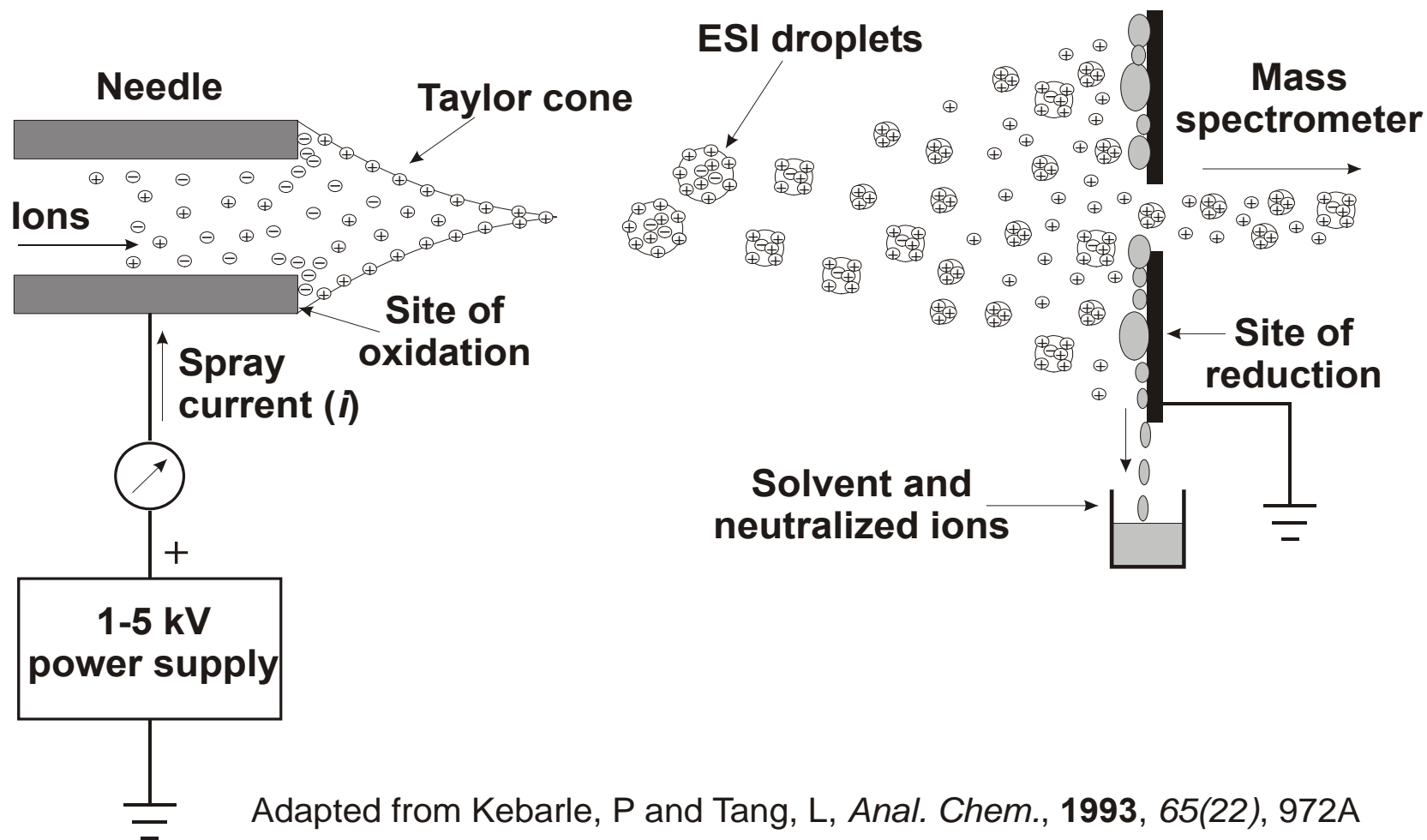

Adapted from Kebarle, P and Tang, L, *Anal. Chem.*, **1993**, 65(22), 972A

MALDI: Matrix Assisted Laser Desorption Ionization

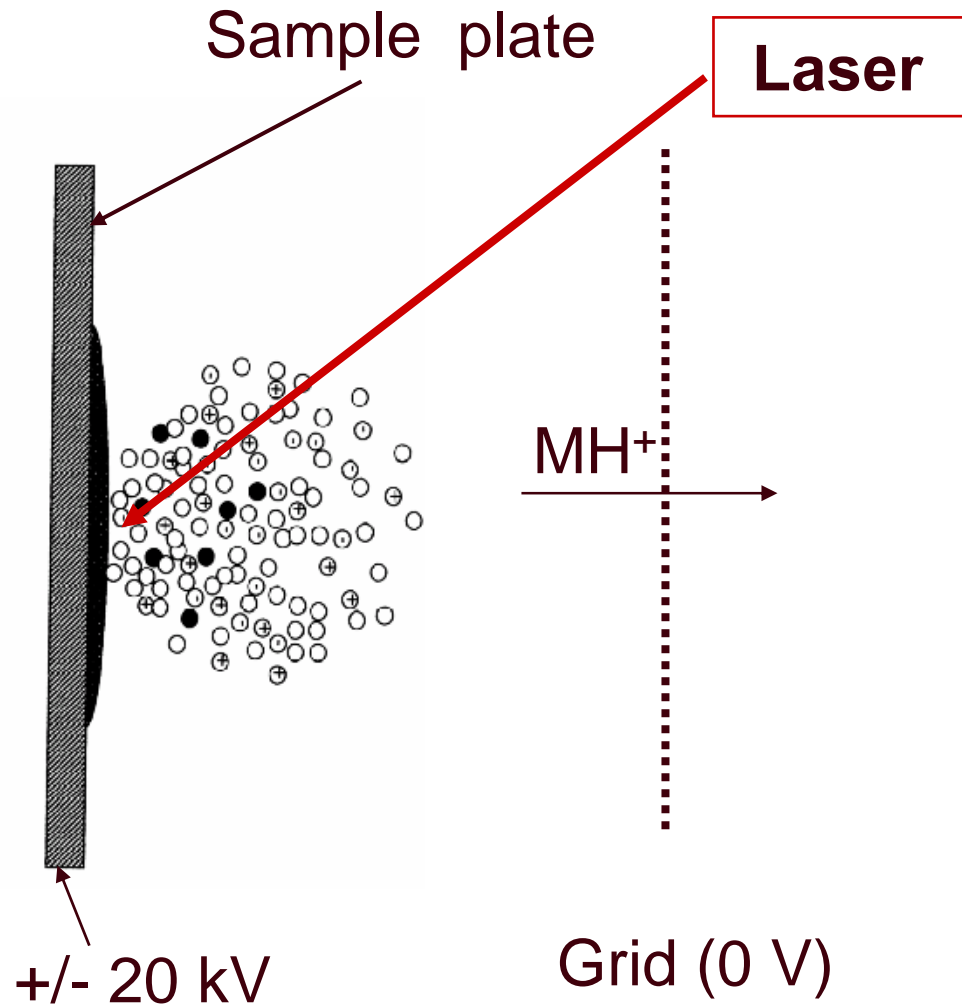

1. Sample is mixed with matrix (X) and dried on plate.
2. Laser flash ionizes matrix molecules.
3. Sample molecules (M) are ionized by proton transfer:
 $\text{XH}^+ + \text{M} \rightarrow \text{MH}^+ + \text{X}$.

MALDI generation of ions

(Matrix-assisted laser desorption ionization)

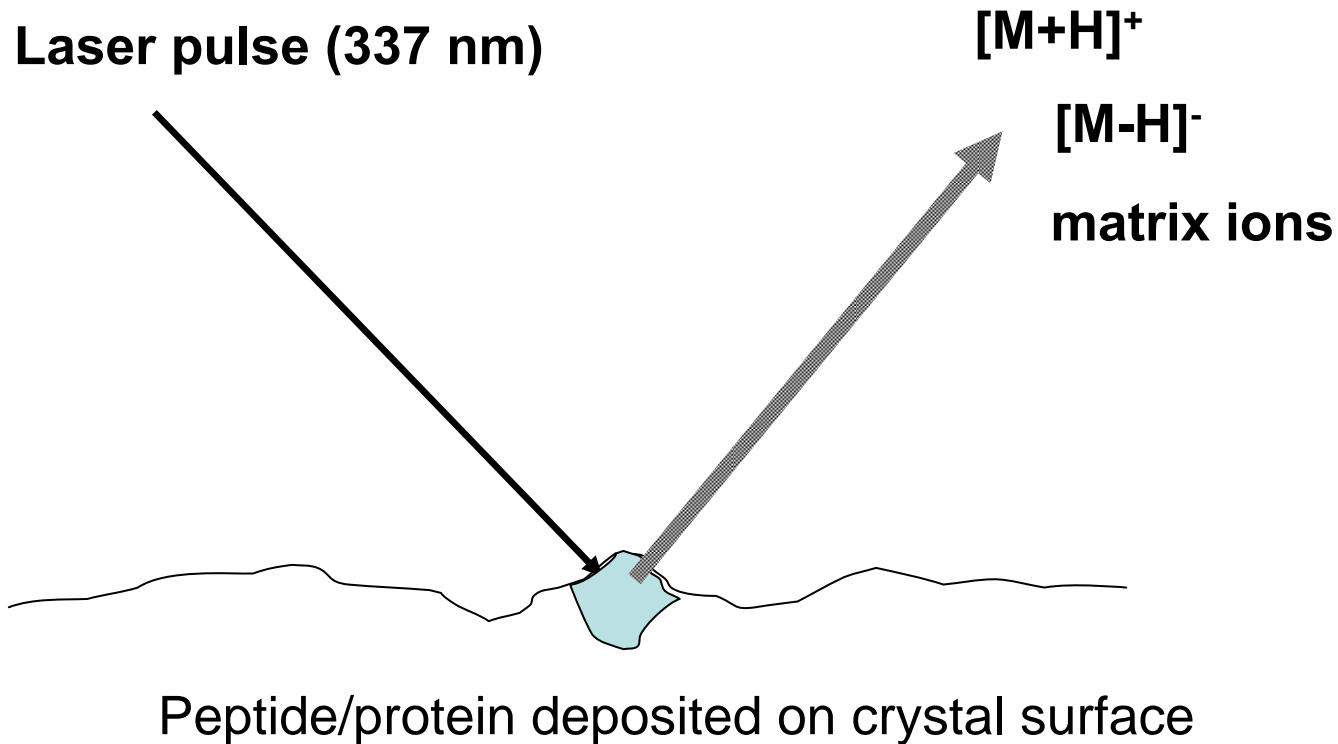

Sample mixed with a UV-absorbing matrix and is allowed to co-crystallize on the metal target.

Matrices for MALDI analysis

Peptides/proteins

- 3,5-dimethoxy-4-hydroxycinnamic acid (sinapinic acid)
- α -cyano-4-hydroxycinnamic acid (CHCA)
- 2,5-dihydroxybenzoic acid (DHB)
- 2-(4-hydroxyphenylazo)-benzoic acid (HABA)

Oligonucleotides

- 2-aminobenzoic acid
- 3-hydroxypicolinic acid (3-HPA)
- 2,4,6-trihydroxyacetophenone (THAP)

The choice of matrix depends greatly on the solute to be analyzed.

Put it in

- We need Ions (+ or -)
- In the gas phase

Your machine

- ToF, ToF / ToF
- Quadrupole, Ion trap
- FT-ICR, Orbitrap (high resolution)
- Hybrids

Tell me the RIGHT answer

- How right is it?

mass resolution and accuracy

Mass Analyzer

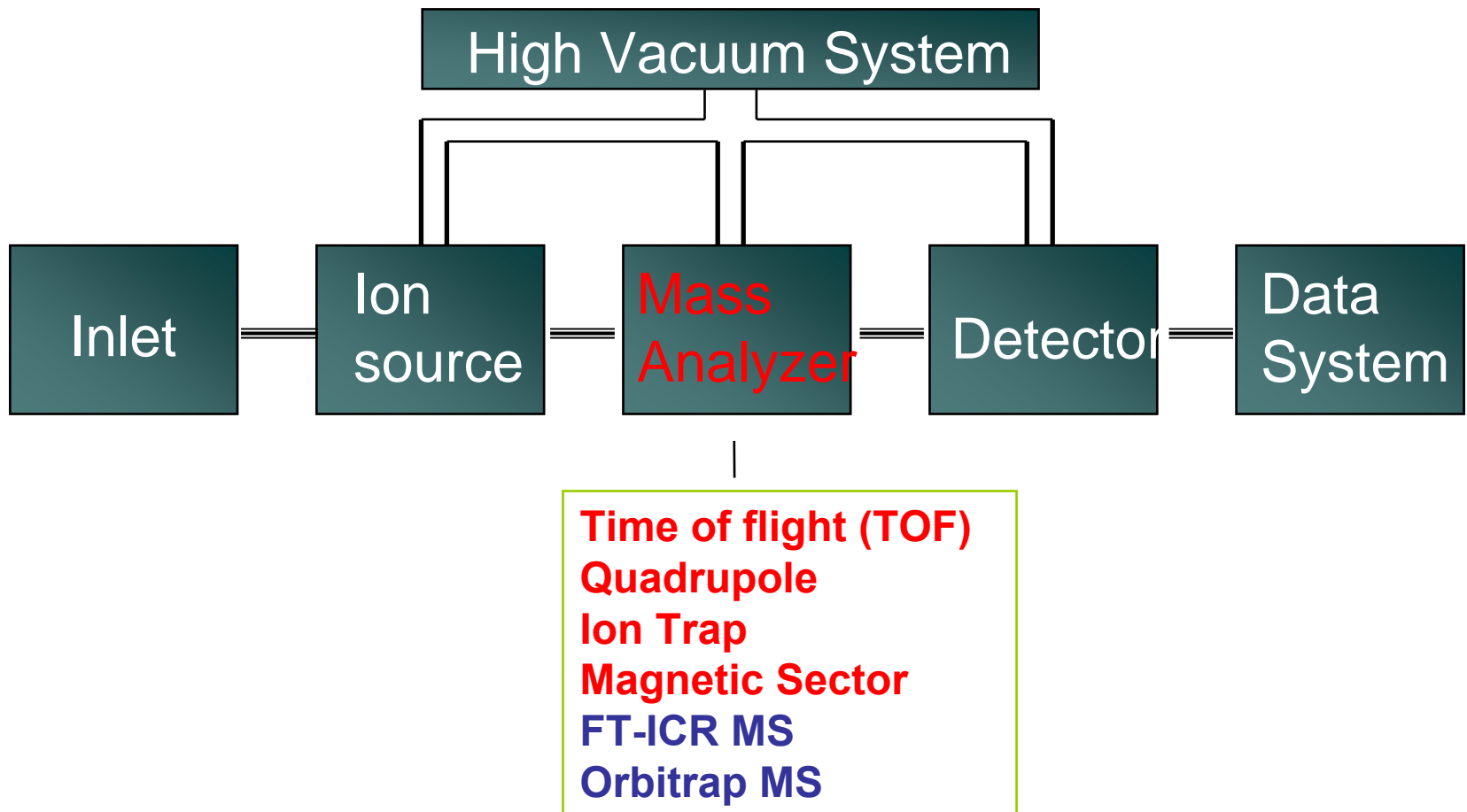

Mass analyzers separate ions based on their mass-to-charge ratio (m/z)

- Operate under high vacuum
(keeps ions from bumping into gas molecules)
- Actually measure mass-to-charge ratio of ions (m/z)

The importance of the mass-to-charge ratio is that according to classical electrodynamics two particles with the same mass-to-charge ratio move in the same path in a vacuum when subjected to the same electric and magnetic fields.

- $\mathbf{F} = m\mathbf{a}$ (Newton's second law of motion)
- $\mathbf{F} = q(\mathbf{E} + \mathbf{v} \times \mathbf{B})$ (Lorentz force Law)
- $(m/q)\mathbf{a} = \mathbf{E} + \mathbf{v} \times \mathbf{B}$
- Key specifications are resolution, mass measurement accuracy, and sensitivity.

Time-of-flight (Tof) analyzer

MALDI

Laser; High Energy
Monochromatic Light Source

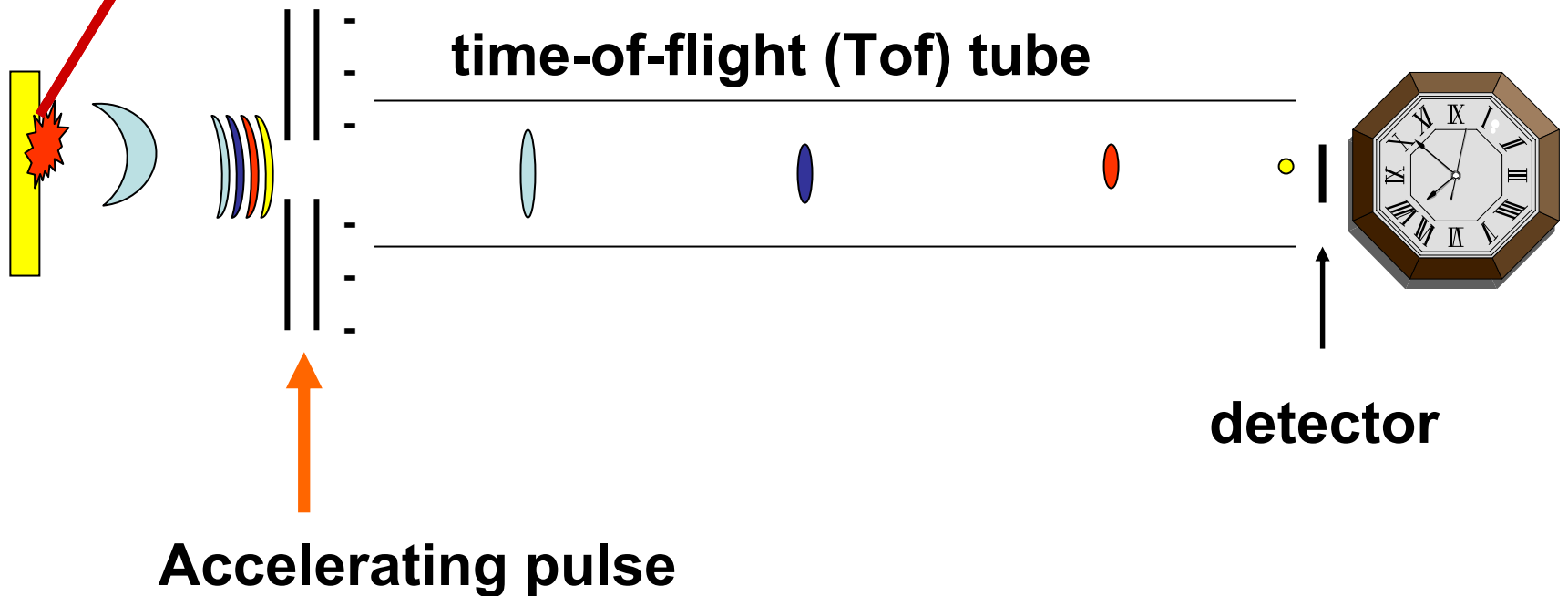

Time-of-flight (TOF) Mass Analyzer

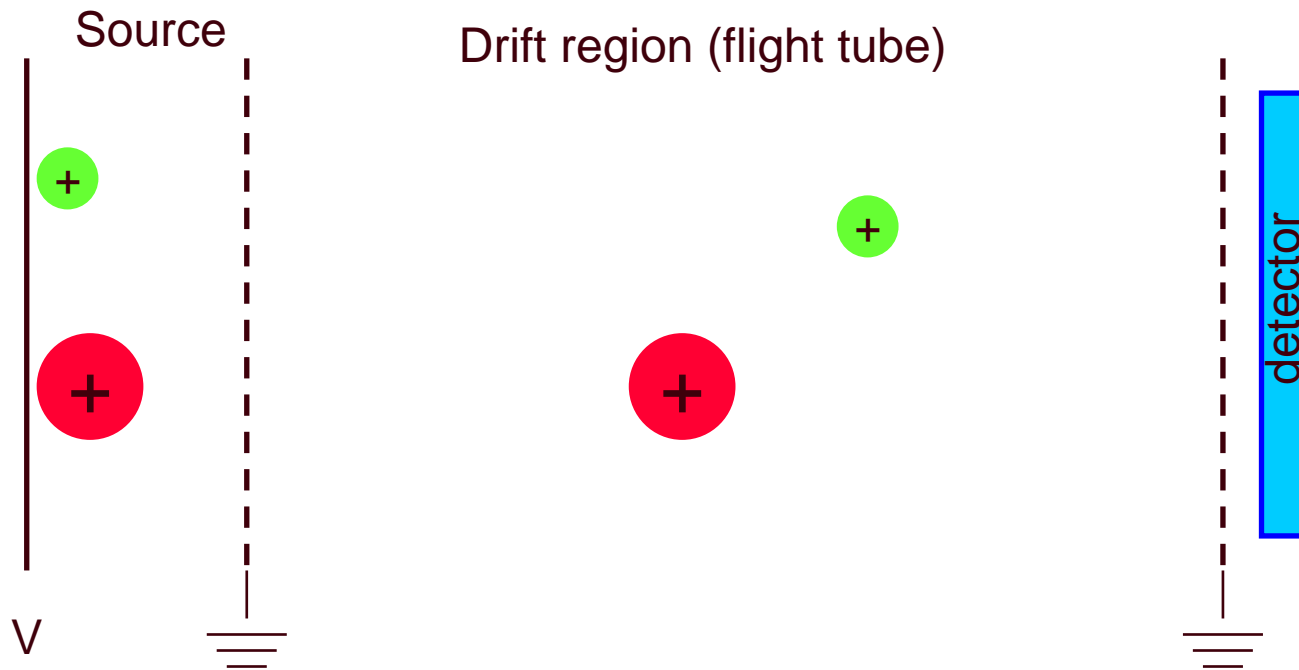

- Ions are formed in pulses.
- The drift region is field free.
- Measures the time for ions to reach the detector.
- Small ions reach the detector before large ones.

Time-of-flight (Tof) analyzer

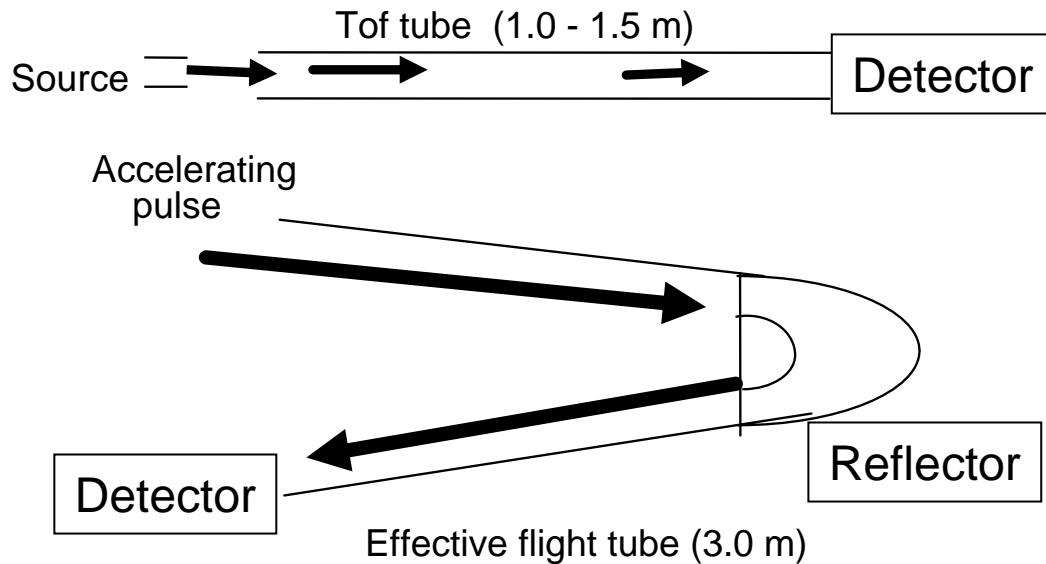

Resolution 2×10^4

No upper limit of mass

Scan times $\sim 1 \mu\text{sec}$, good for LC-MSMS

Ions are accelerated so that they have equal kinetic energy. The ions “drift” down a 1 - 1.5 meter tube before striking a photomultiplier detector. “time of flight” (t) depends on the mass of the ion (m), where $t = (m/2eV)^{1/2} \cdot D$

V is the applied potential and D is the flight tube distance. For a given instrument, the flight time varies as the square root of the mass of the ion.

Principals of the MALDI-ToF/ToF 4700

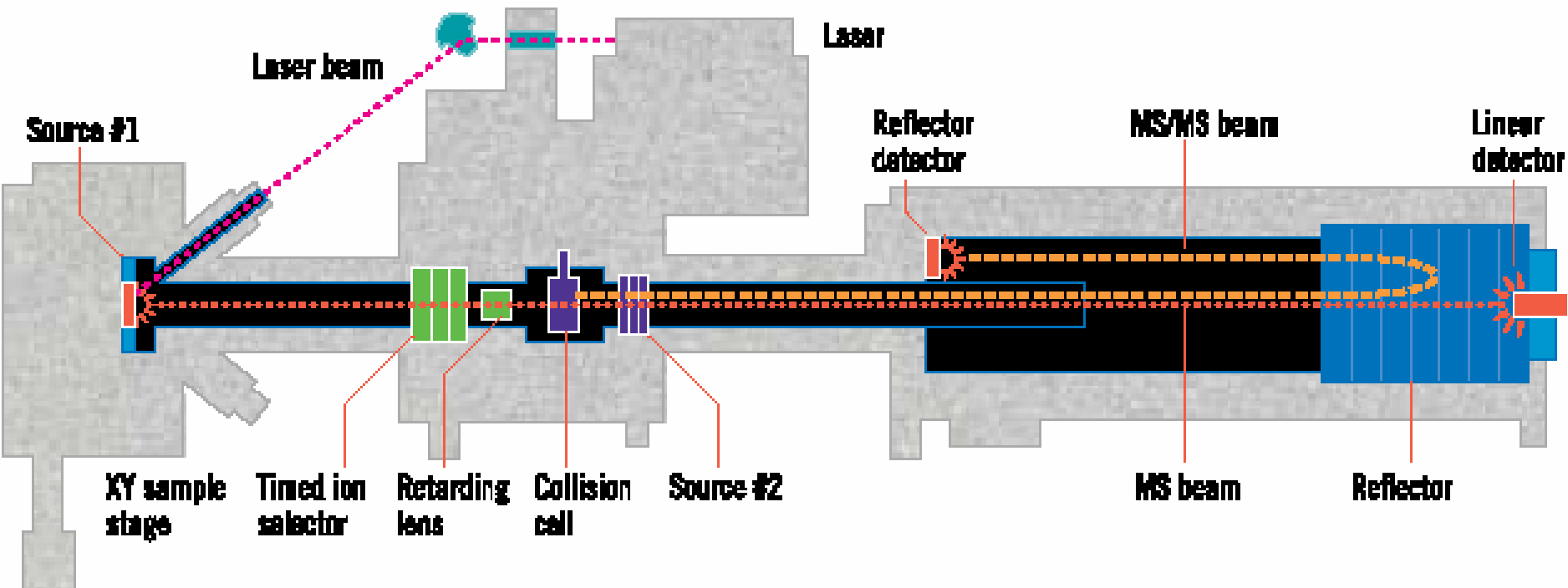

QSTAR™ ESI QQ TOF or MALDI QQ TOF

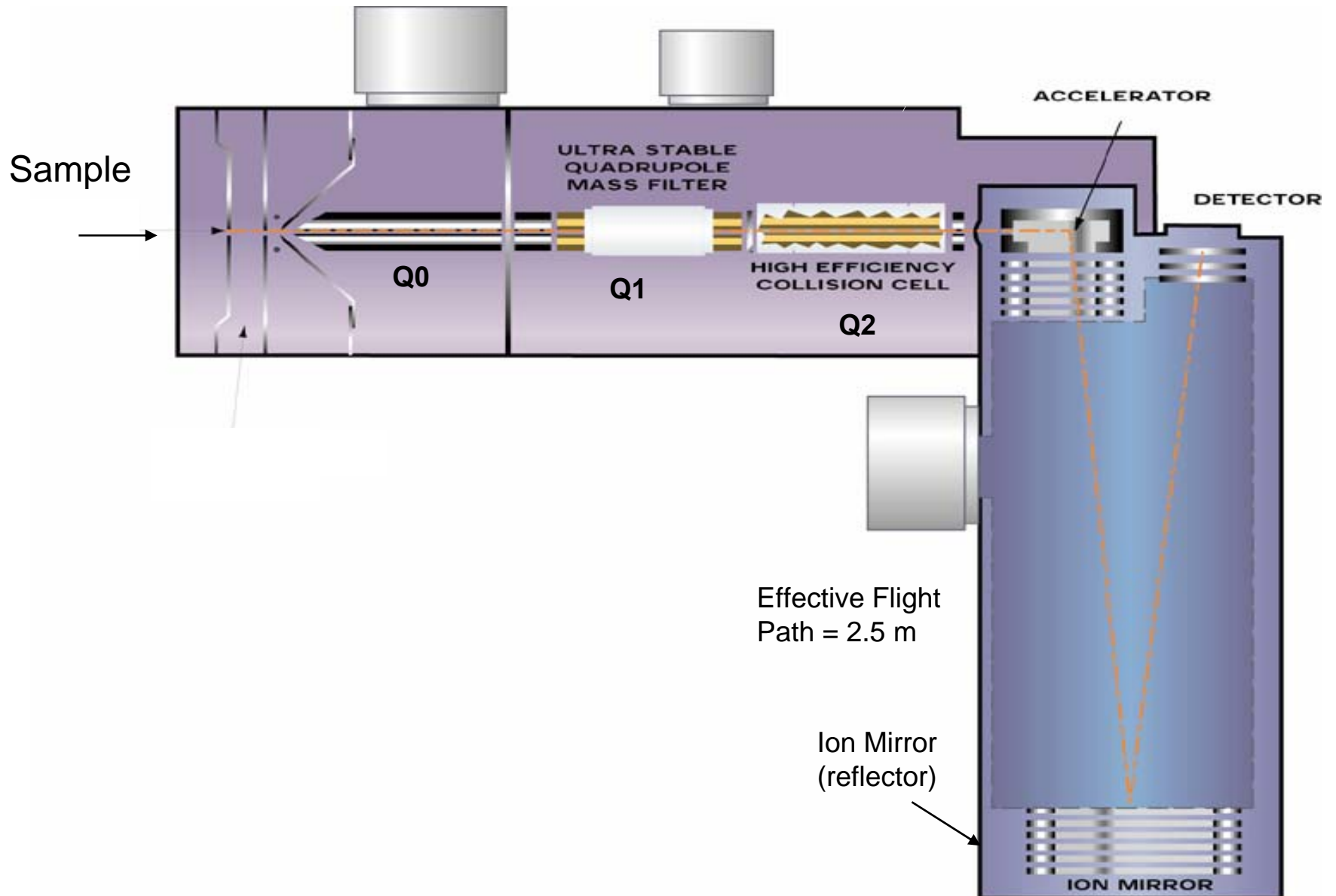

Quadrupole Mass Analyzer

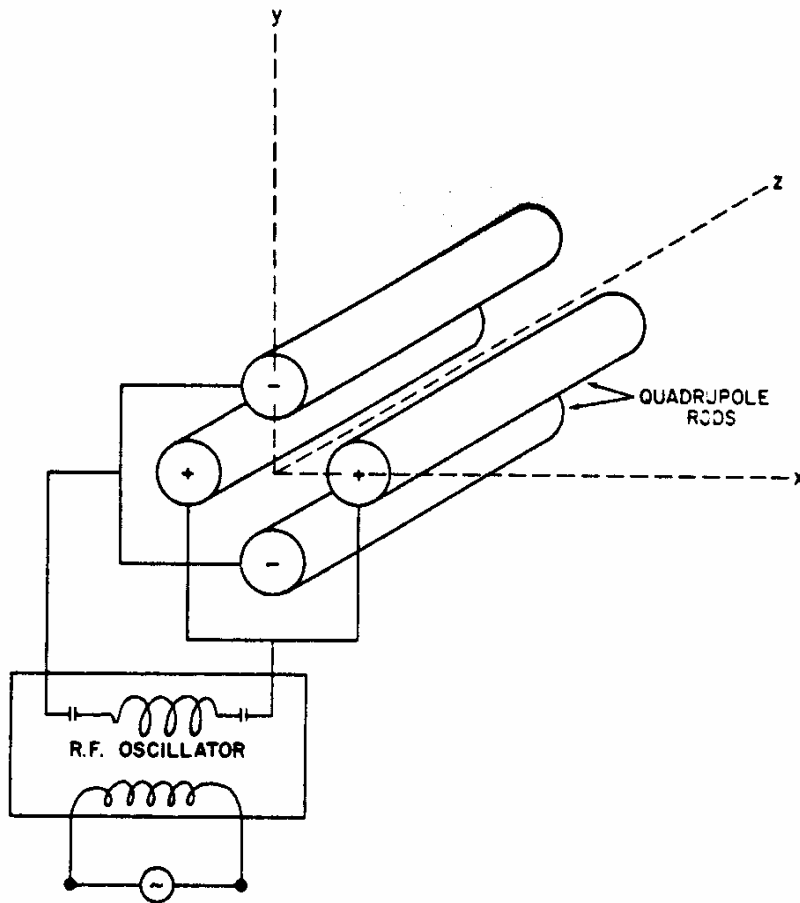

Uses a combination of RF and DC voltages to operate as a mass filter.

- Has four parallel metal rods.
- Lets one mass pass through at a time.
- Can scan through all masses or sit at one fixed mass.

Quadrupoles have variable ion transmission modes

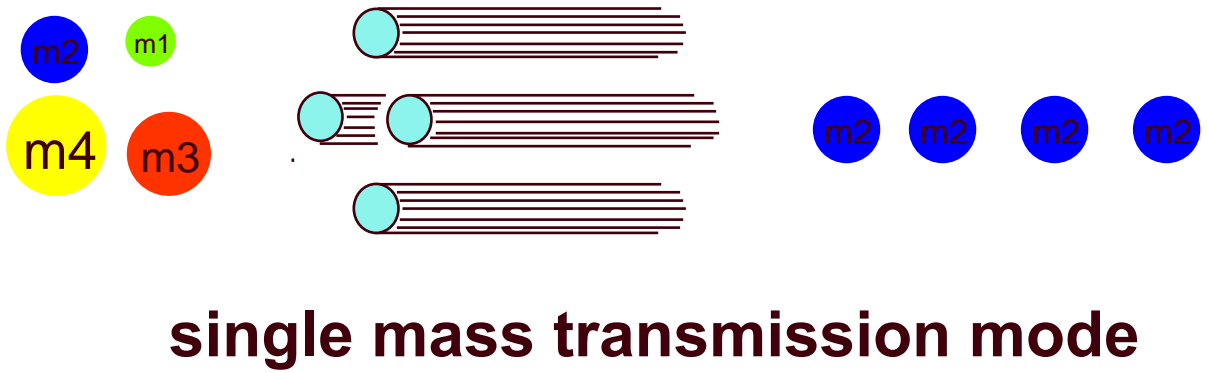

Quadrupole mass filter / ion guide

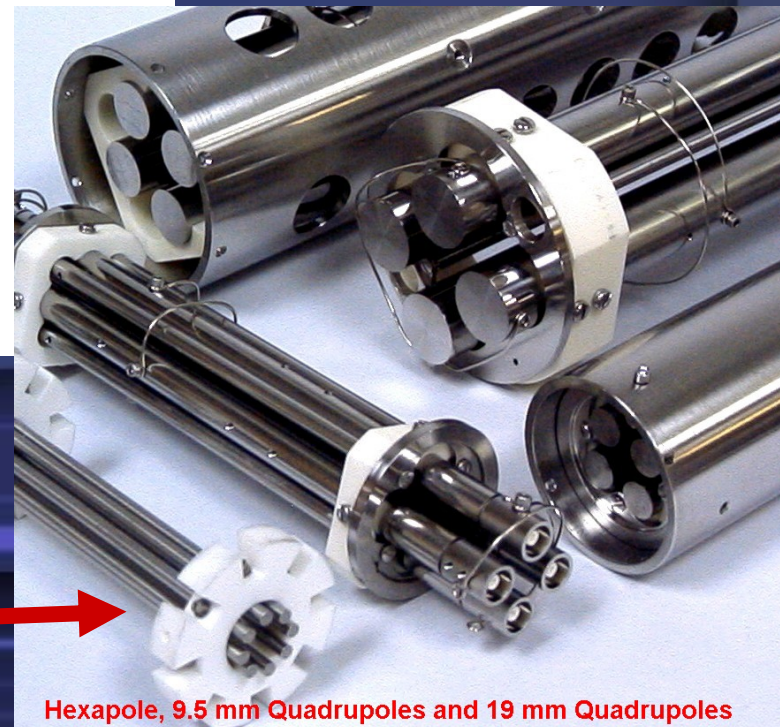
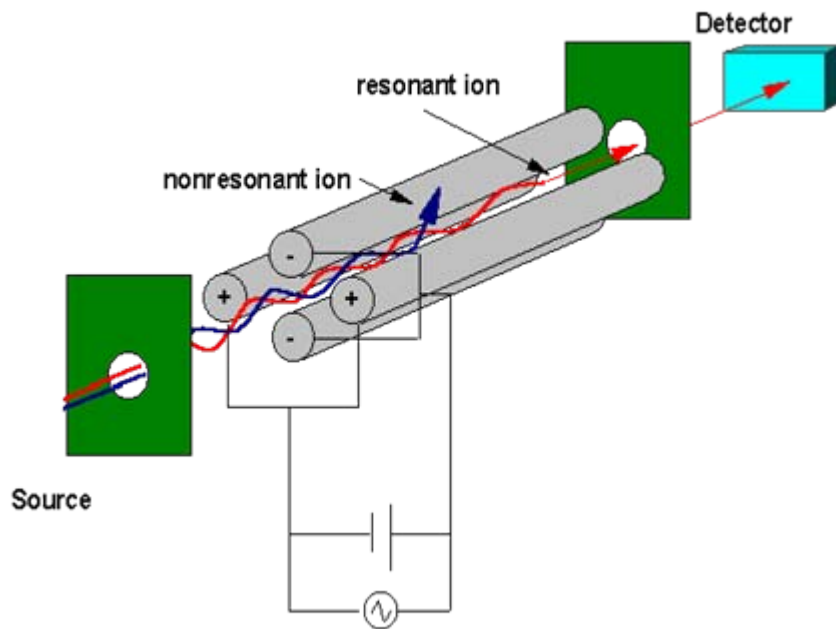

Octapole



Hexapole, 9.5 mm Quadrupoles and 19 mm Quadrupoles

Quadrupole analyzer

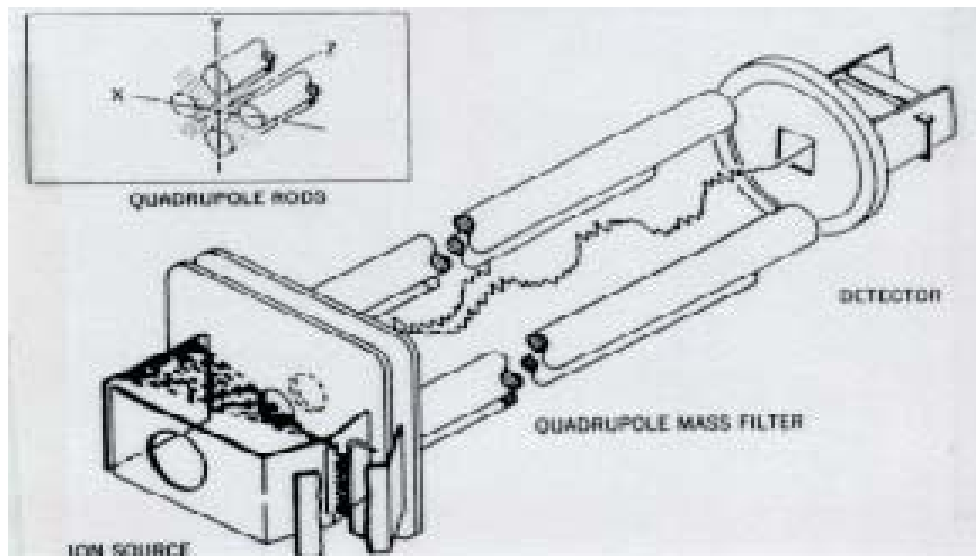

Mass resolution 2×10^3

Tolerant of relatively high pressure (10^{-4} torr)

Upper limit for m/z is 3,000-4,000

Ions are accelerated electrically (5-15V) and passed along the long central axis of four rods arranged symmetrically.

By applying combined DC and oscillating RF potentials, the ions drift along irregular flight paths along the rod axis. The DC/RF ratio is held constant and the absolute values of DC and RF are varied.

Only ions with a particular m/z value have stable trajectories for a given value of DC and RF.

If DC is set to 0, then all ions have stable trajectories. *A scan can be accomplished over a period of 10-1000 msec.*

QTRAP: Linear Ion Trap on a Triple Quadrupole

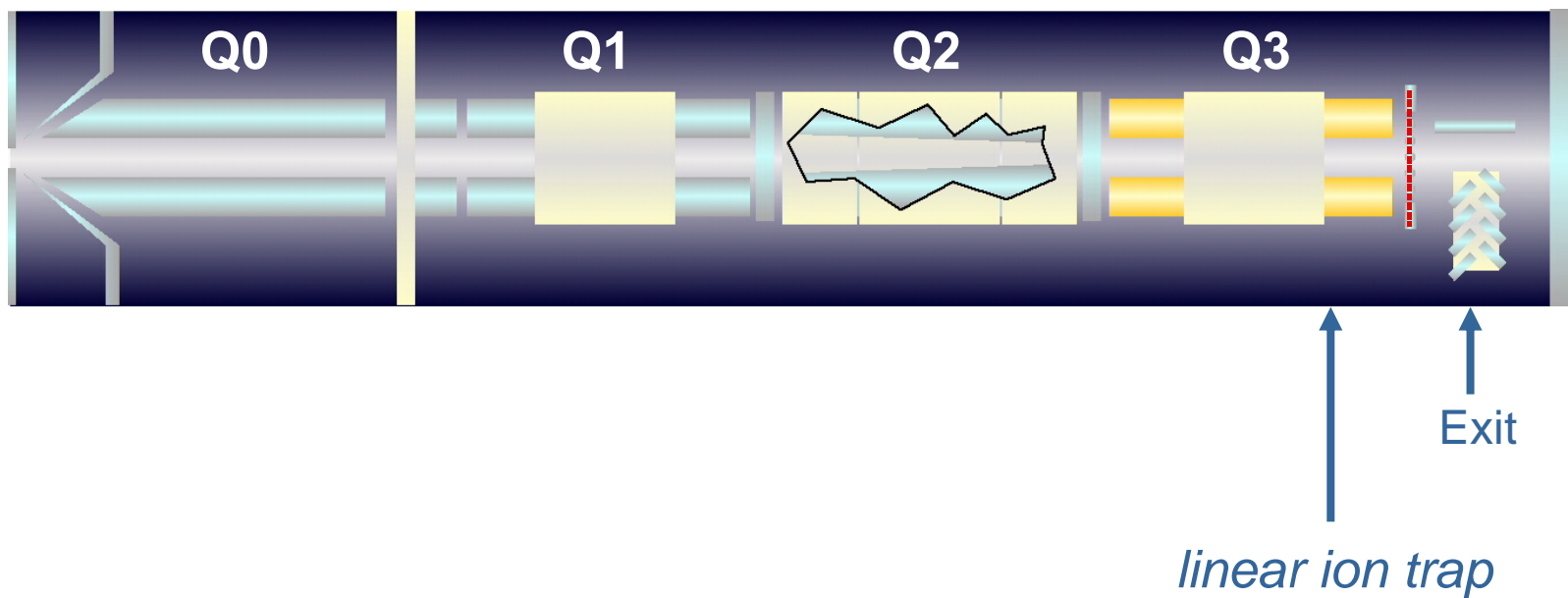

Ion Traps



The ion trap is an energy well - ions with sufficient energy to enter the trap are retained by an energy barrier on the exit side of the trap. The advantage of the ion trap is that it accumulates selected ions prior to their analysis giving it high initial sensitivity (detection limit of approx. 20 fmol).

Ions are fragmented by collision with helium gas and their daughter ions analyzed within the trap. Selected daughter ions can undergo further fragmentation, thus allowing MS^n .

The ion trap has a high efficiency of transfer of fragment ions to the next stage of fragmentation (unlike the triple quadrupole instrument).

Expanded view of 3D ion trap

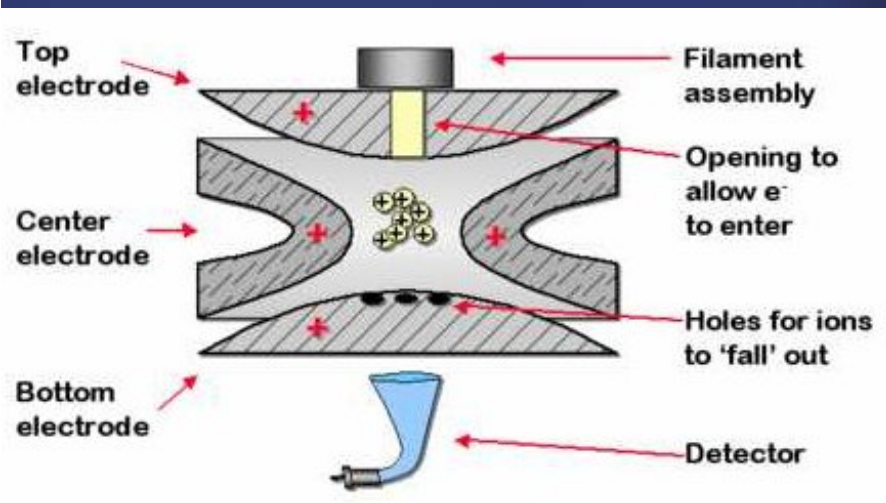
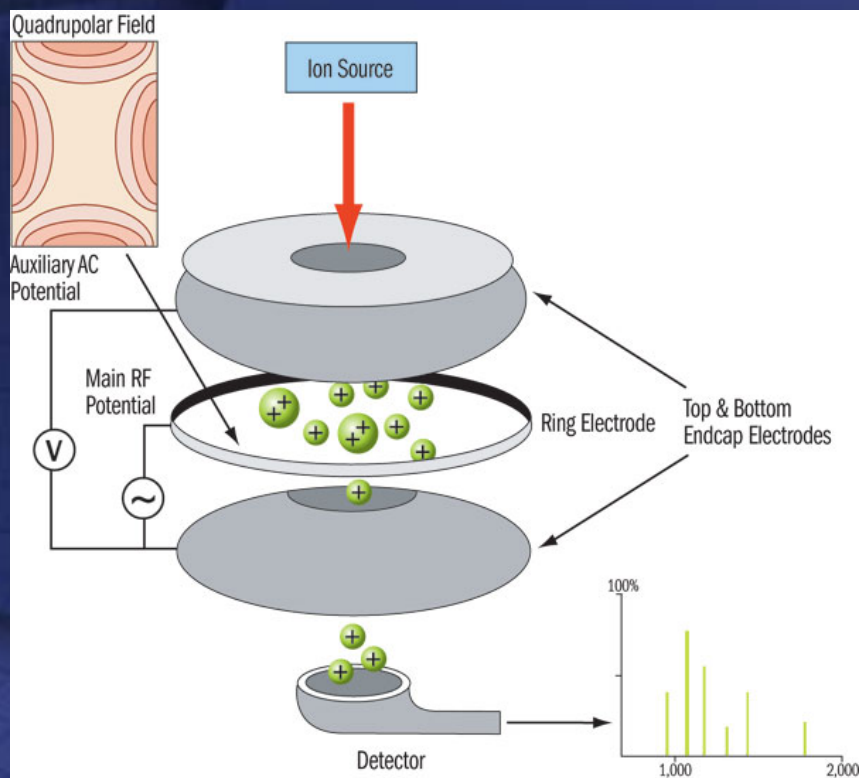

3D ion trap and 2D ion trap

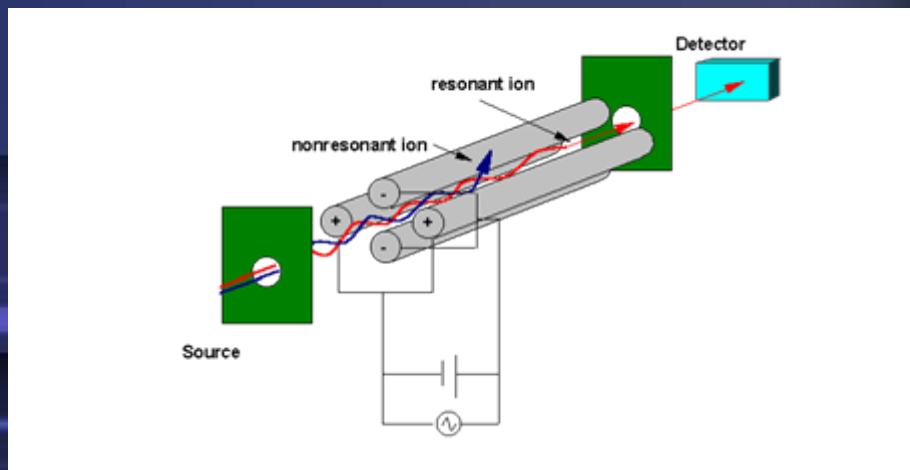
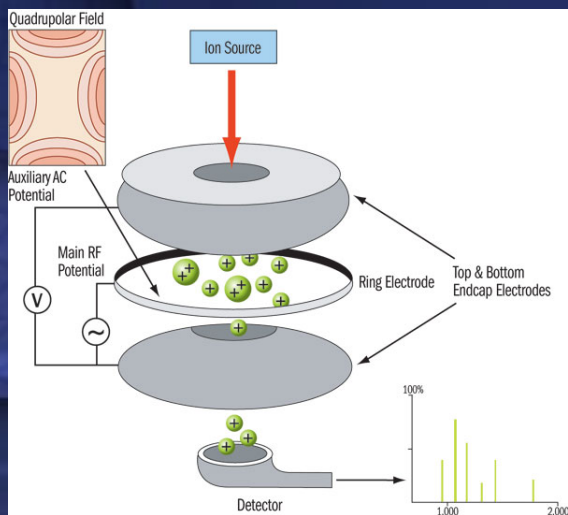

2D ion trap detection

Thermo
ELECTRON CORPORATION

FINNIGAN **LTQ**

Conversion dynodes

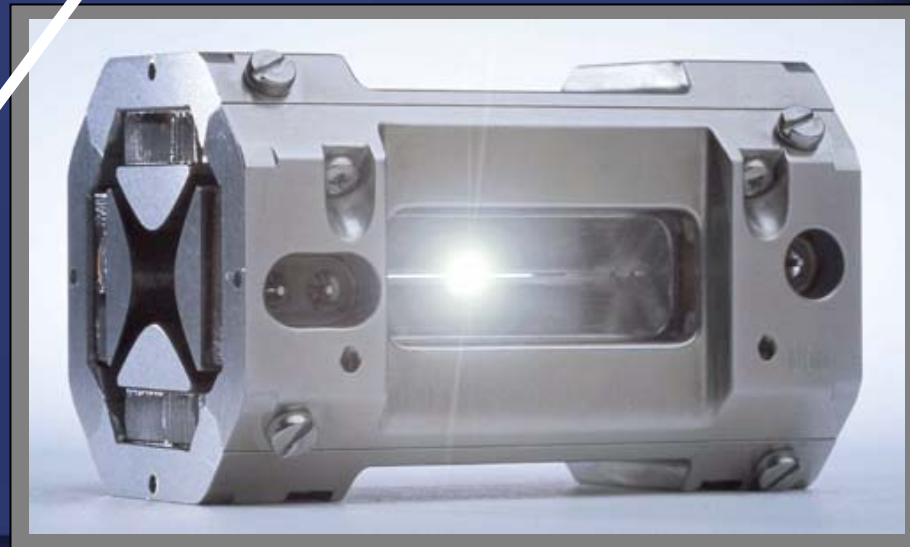
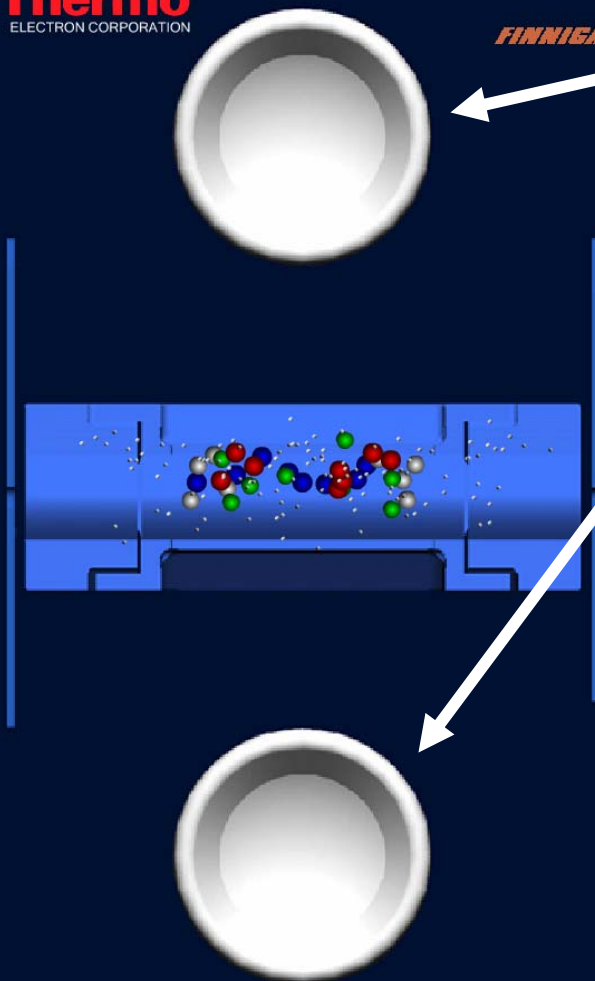

Penning Trap (ICR cell)

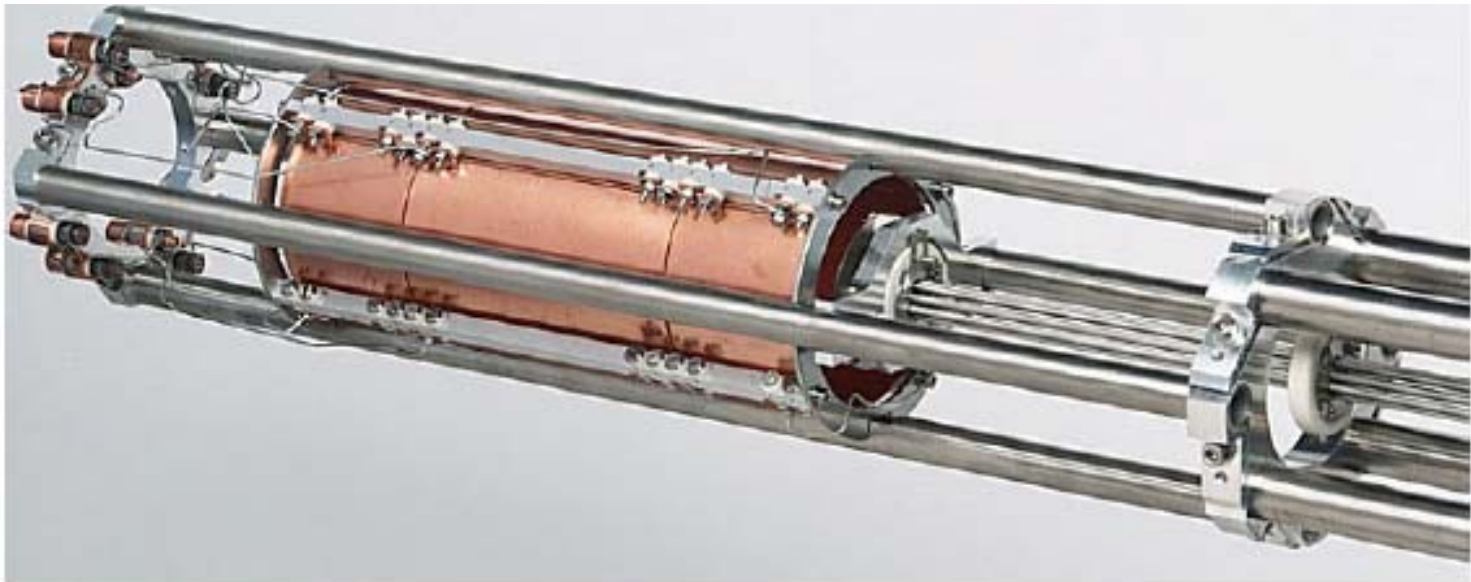

Penning Trap (ICR cell)

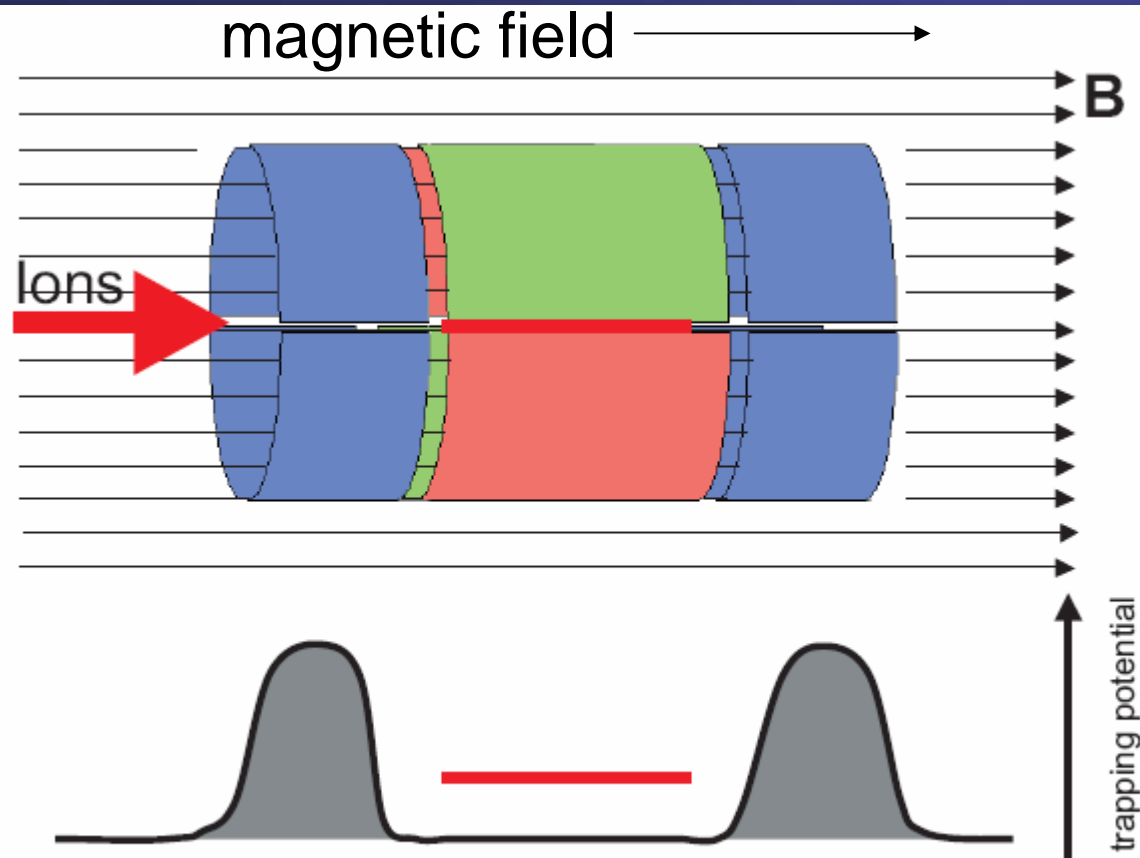
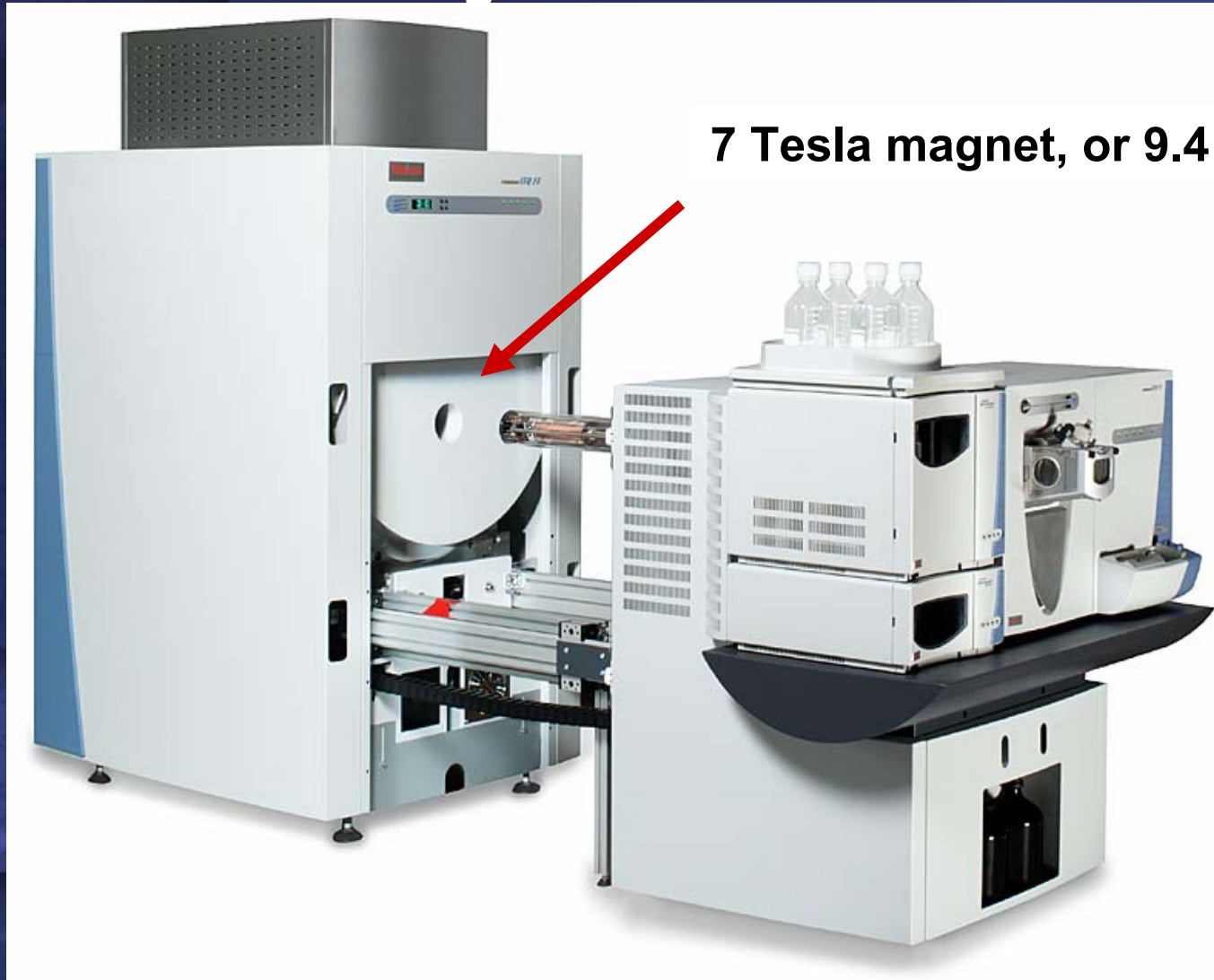
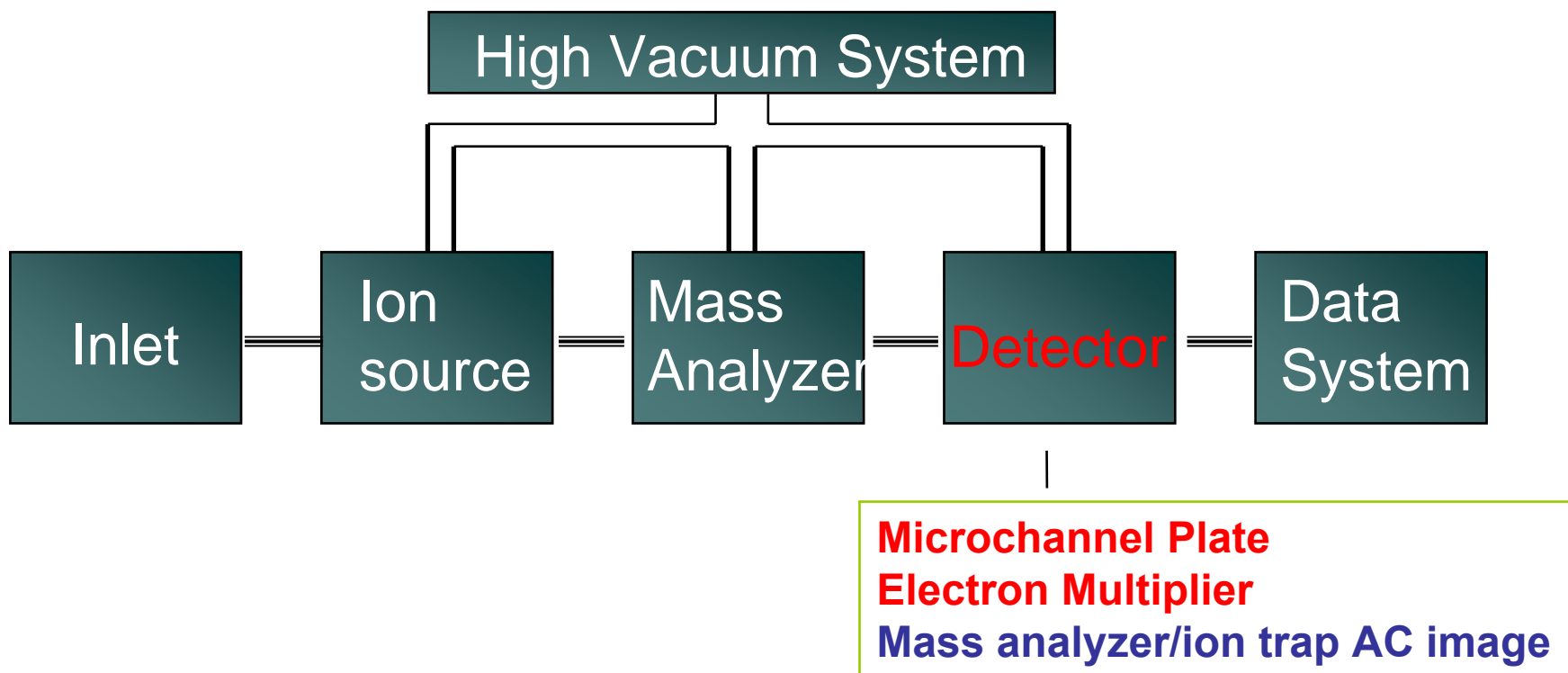

Figure 1-14. Operating principle of the Penning trap

Put the trap in a high magnetic field Ion cyclotron resonance



Detector



3D ion trap and 2D ion trap

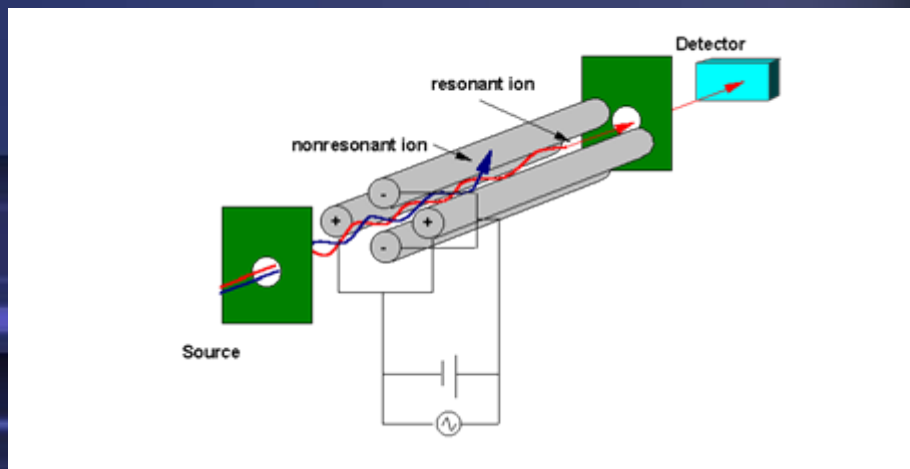
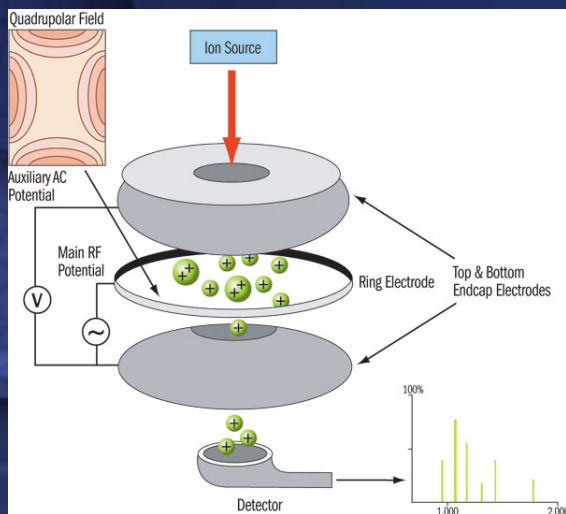

2D ion trap detection

Thermo
ELECTRON CORPORATION

FINNIGAN **LTQ**

Conversion dynodes

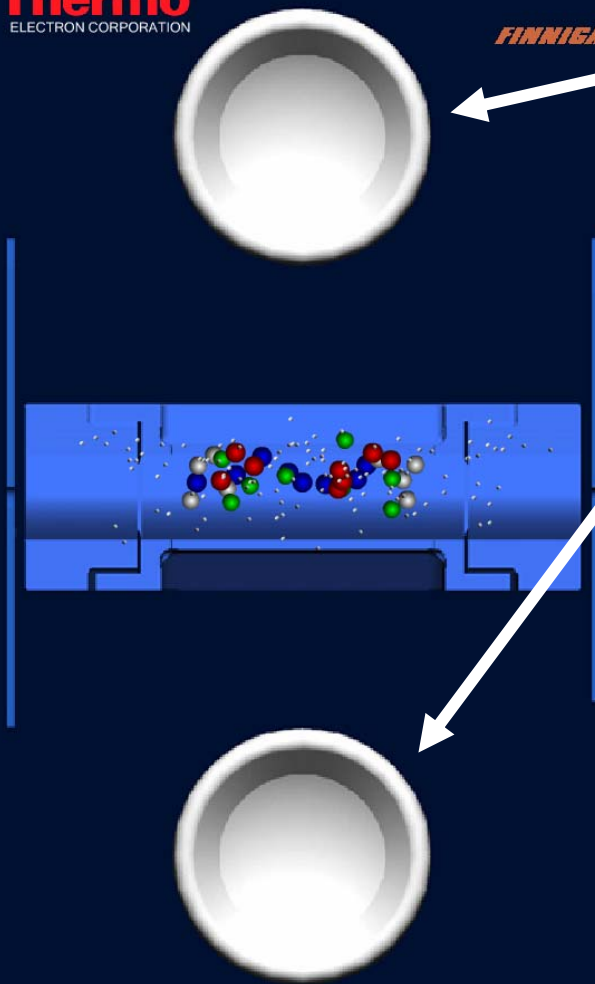

2D ion trap detection

Thermo
ELECTRON CORPORATION

FINNIGAN LTQ

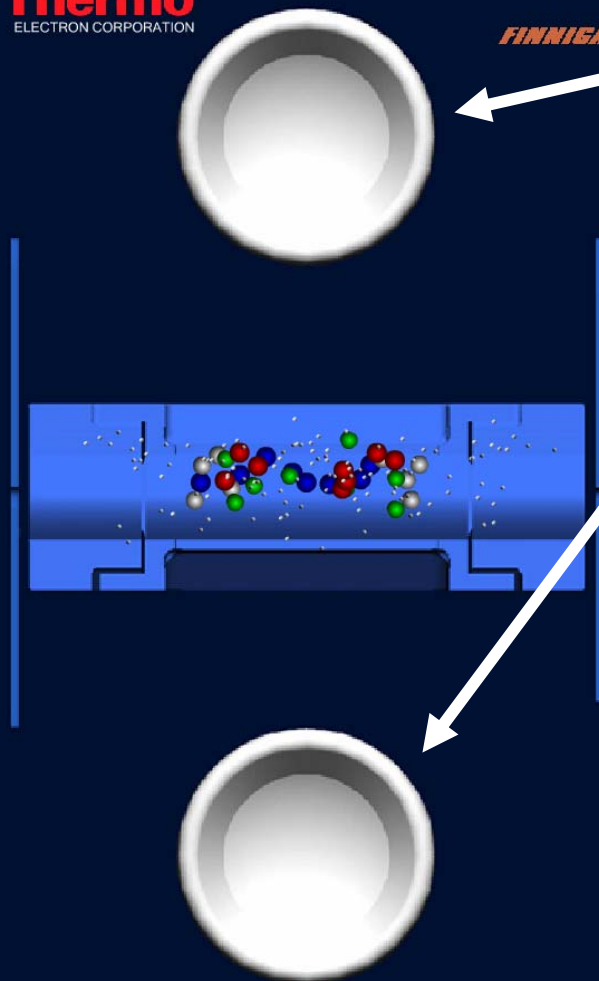

Conversion dynodes (electron multipliers)

Principle of the (Discrete) Electron Multiplier

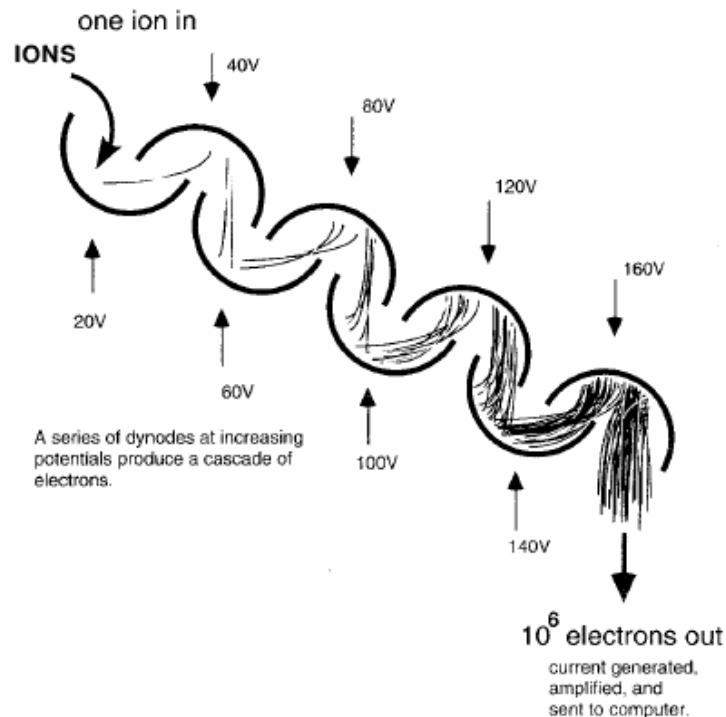

From Siudzak

Principle of the (Discrete) Electron Multiplier

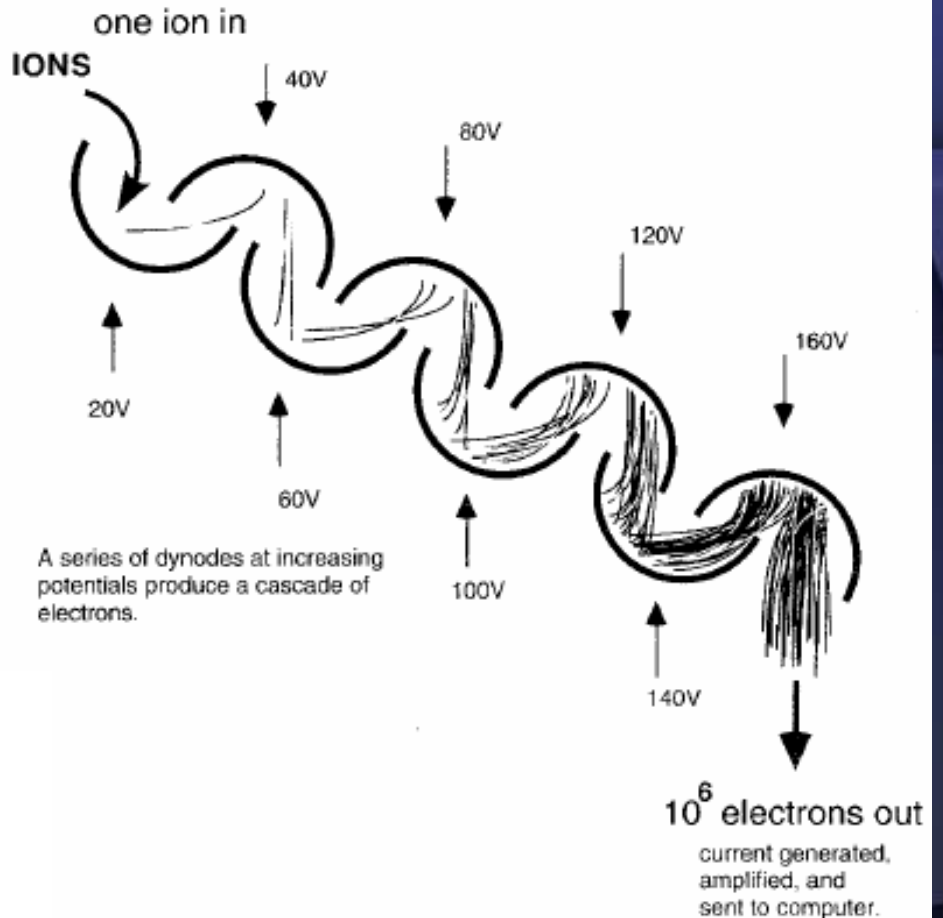

Continuous Dynode Electron Multiplier

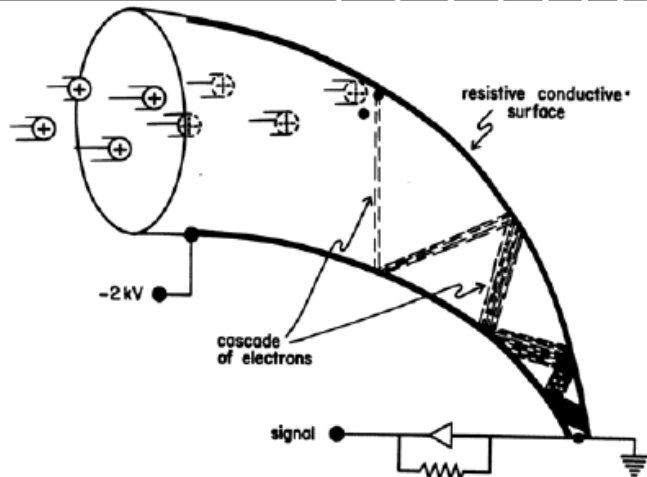

From Watson

FIG. 13.3. Conceptual diagram of a nonmagnetic electron multiplier; the field gradient along the resistive conductive internal surface of the cornucopia attracts the cascading electrons toward the preamplifier.

Detecting in the ion trap Ion cyclotron resonance (ICR)

7 Tesla magnet, or 9.4 T or 12 T or 14.5 T



Fourier transform- ion cyclotron resonance FT-ICR MS

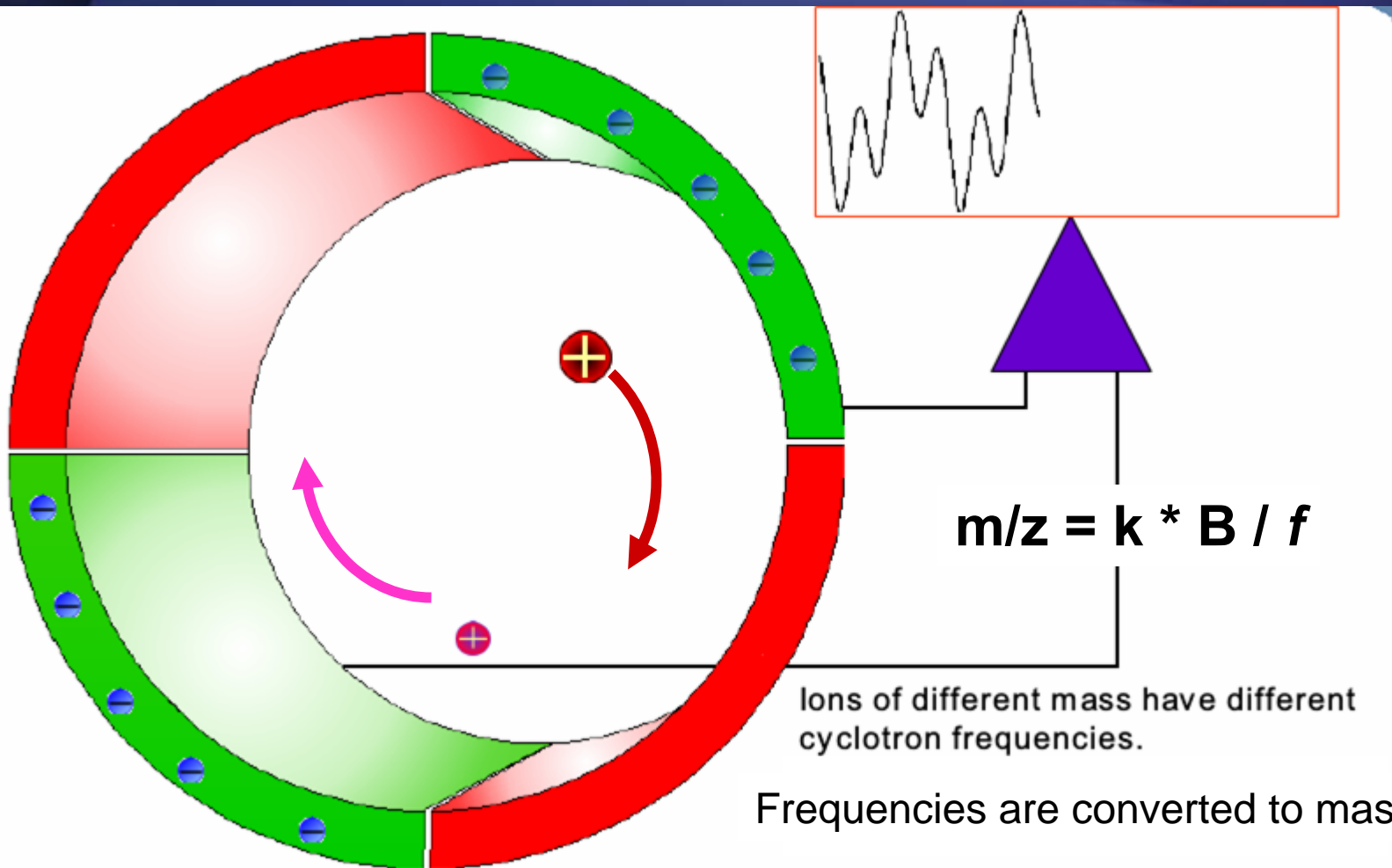

$$m/z = k * B / f$$

Ions of different mass have different cyclotron frequencies.

Frequencies are converted to masses.

ThermoFinnigan LTQ-FT

Linear Ion Trap MS

- MS, MS/MS and MSⁿ Analysis
- AGC Control
- Secondary Electron Multiplier **Detector**

Linear Ion Trap Data

FTICR MS

- Ion Image Current **Detector**
- Accurate Mass
- High Resolution

FTMS Data

7 T Actively Shielded
Superconductive Magnet

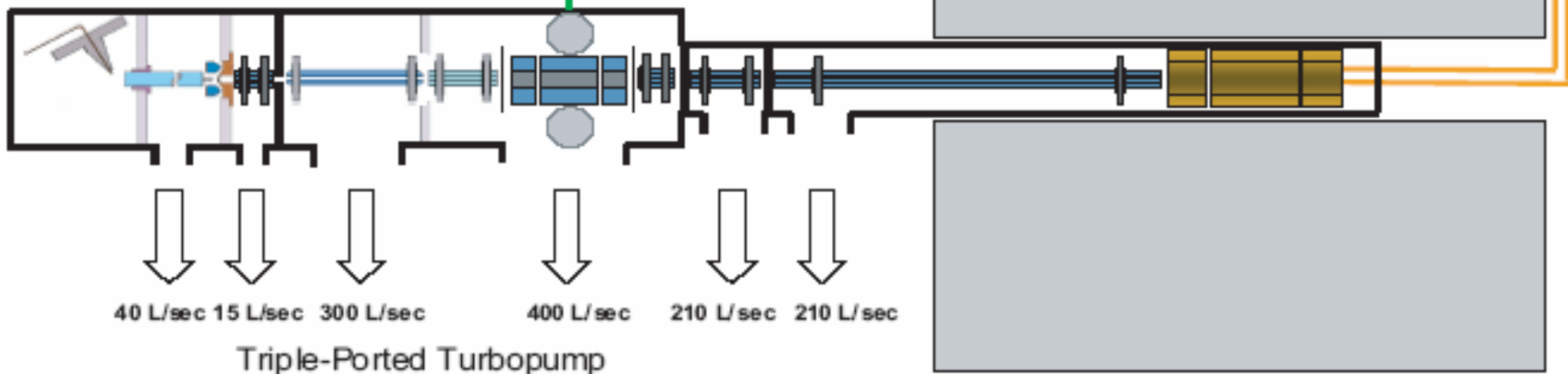

LTQ Orbitrap™ Hybrid Mass Spectrometer

..... Finnigan LTQ™ Linear Ion Trap

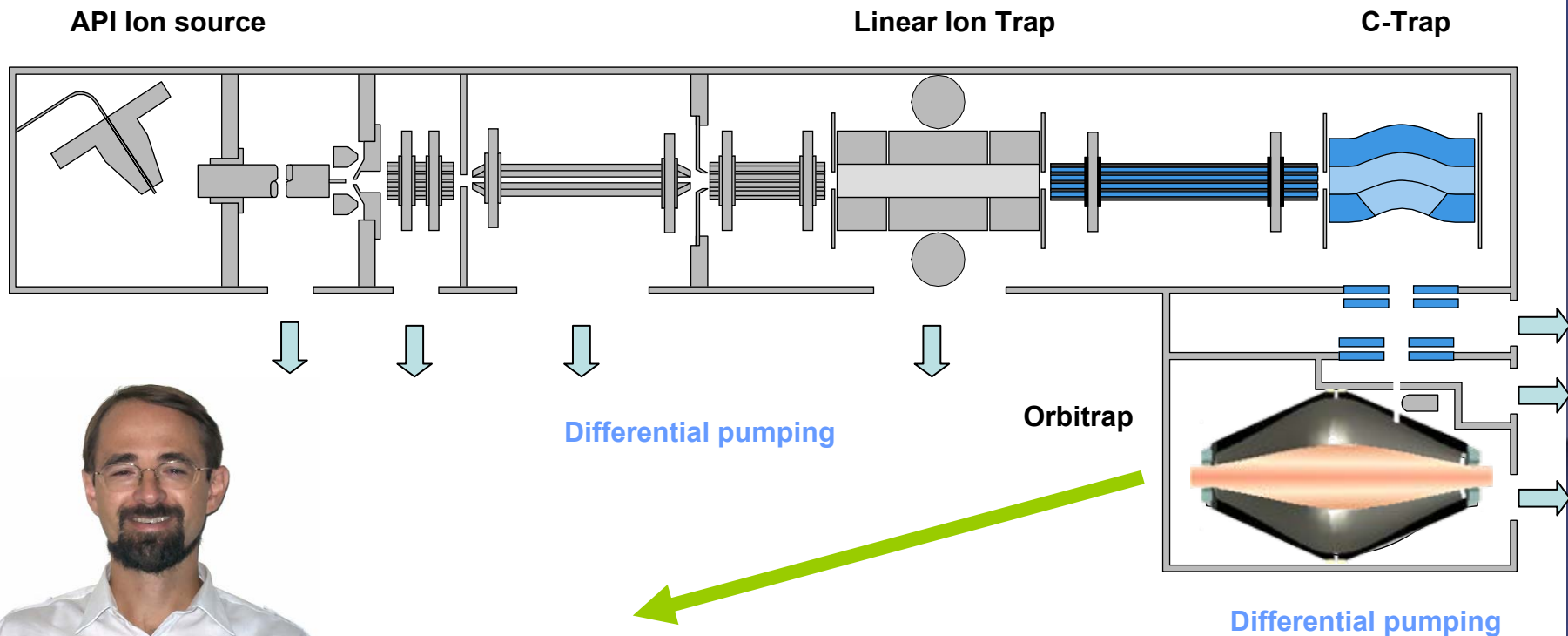

Inventor: Dr. Alexander Makarov, Thermo Electron (Bremen)

Orbitrap Mass Analyzer

Orbitrap: A Breakthrough Electrostatic Ion Trap

- Highest ion trapping efficiencies
- Large ion capacity
- Stable and robust operation
- Patented analyzer technologies

$$\omega = \sqrt{\frac{k}{m/z}}$$

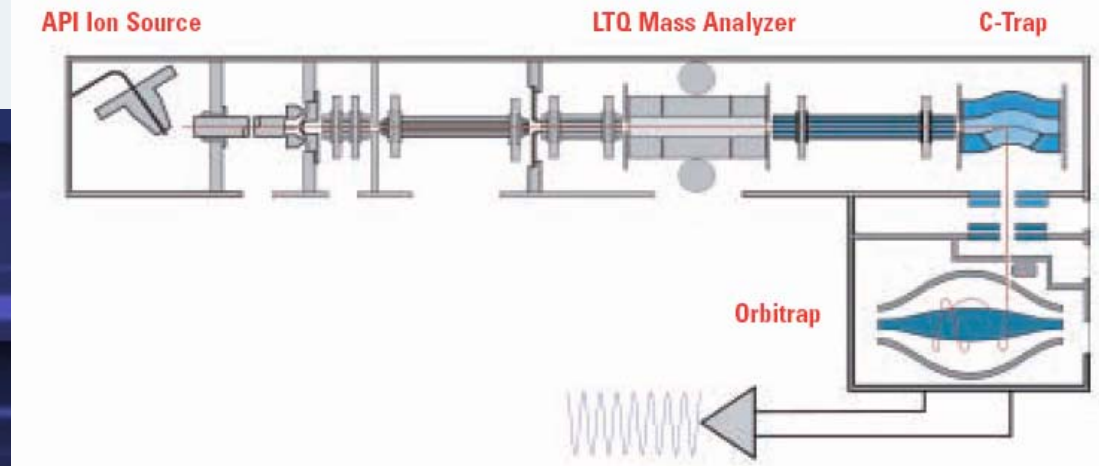
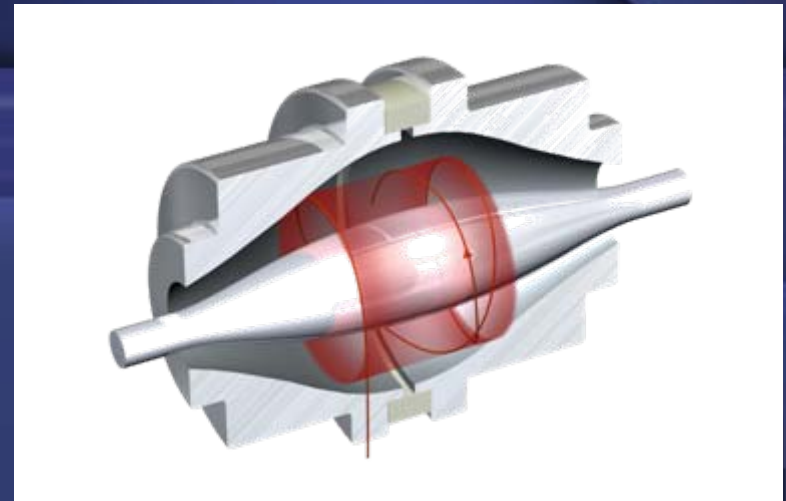
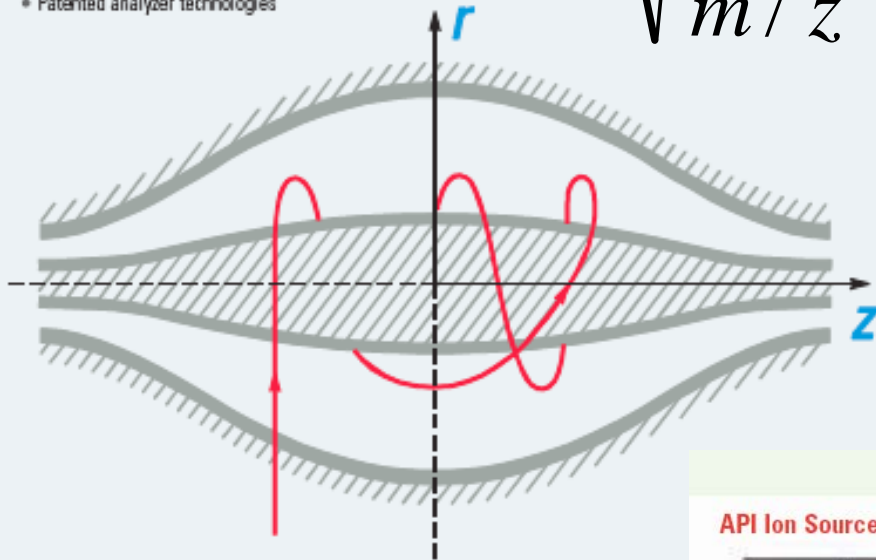

Data System

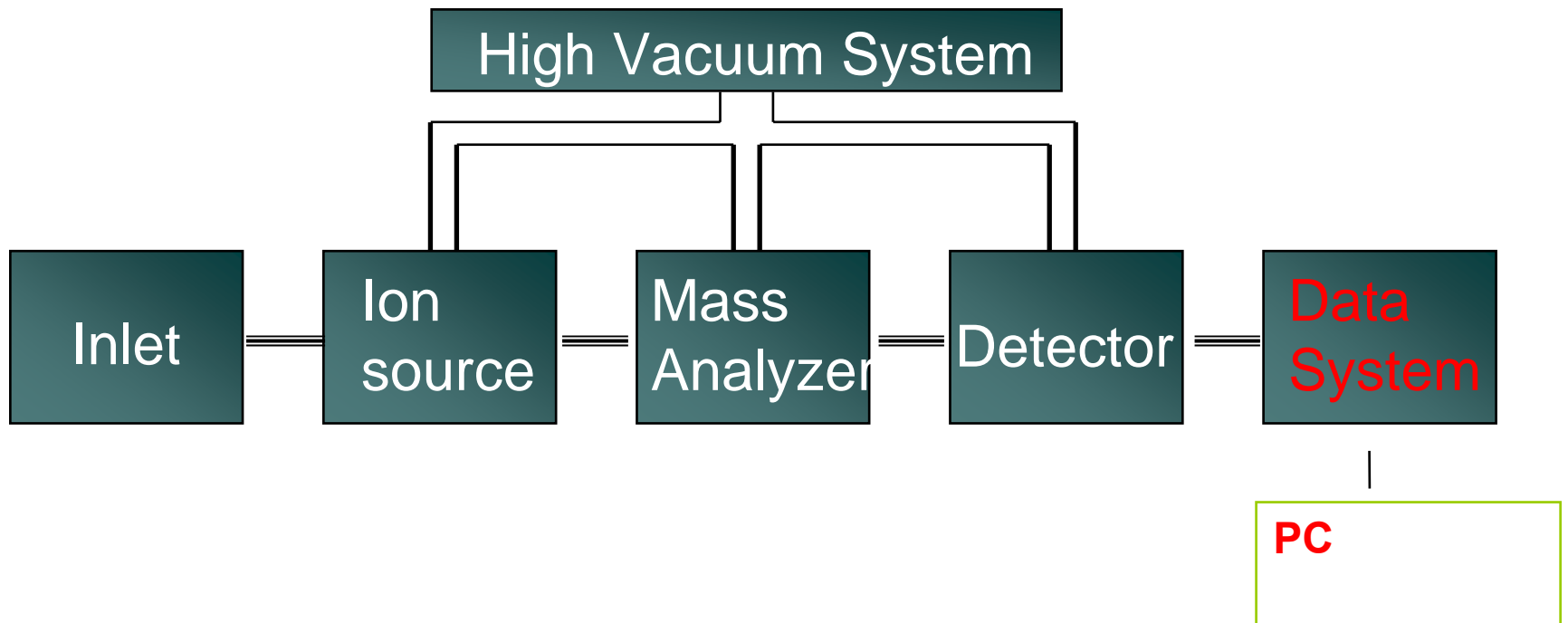

The mass spectrum shows the results

MALDI TOF spectrum of IgG

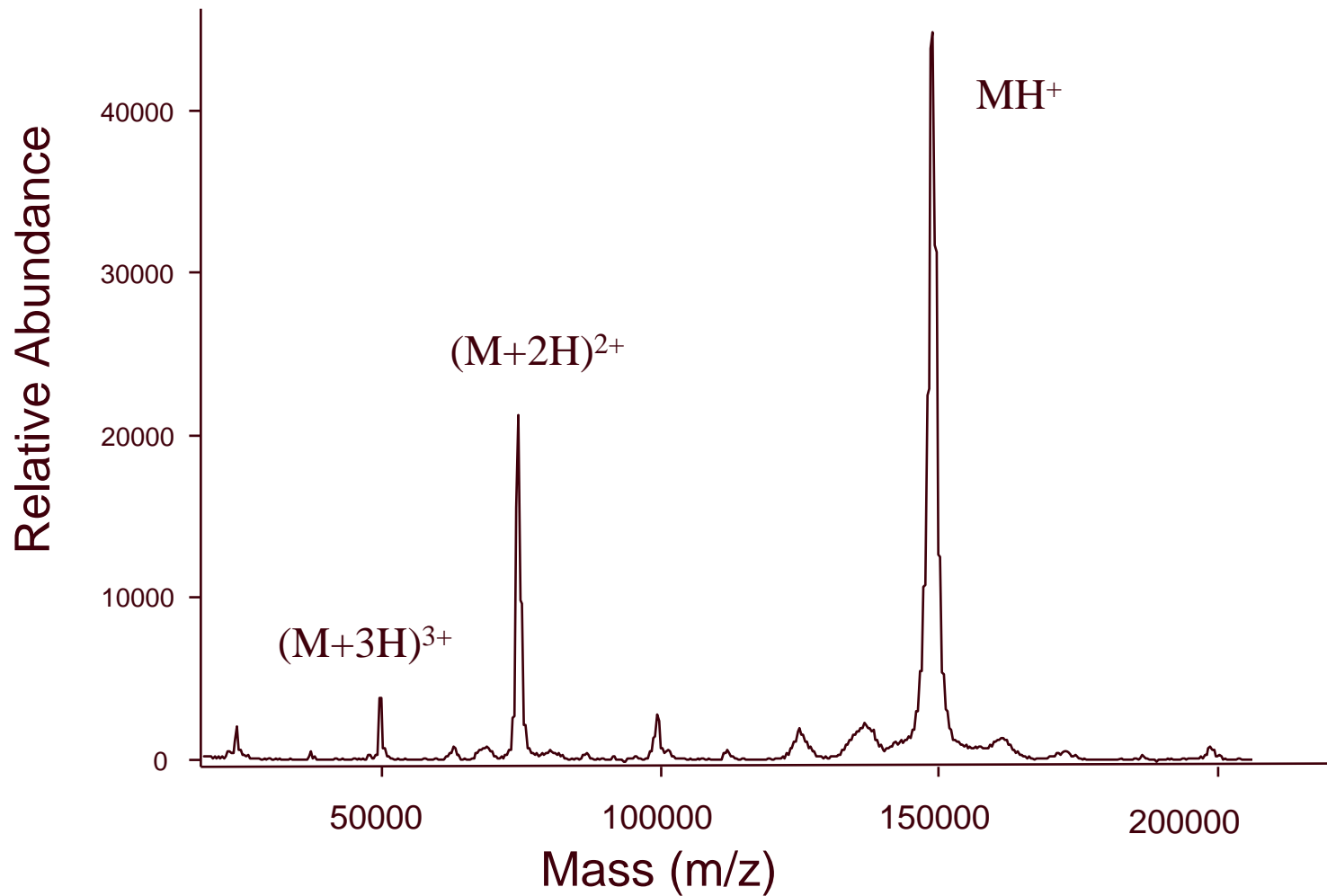

ESI Spectrum of Trypsinogen (MW 23983)

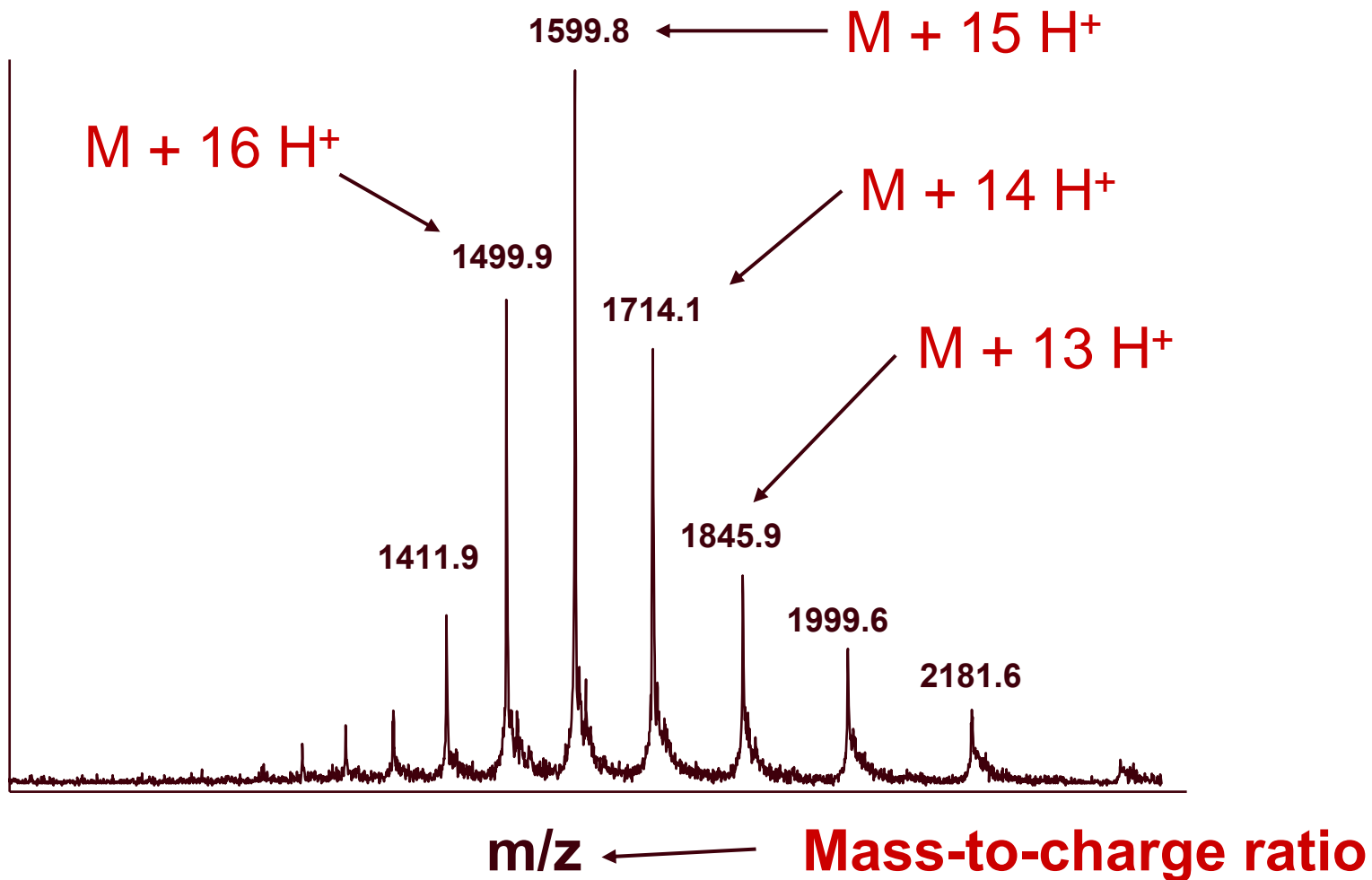

How do mass spectrometers get their names?

Types of ion sources:

- Electrospray (ESI)
- Matrix Assisted Laser Desorption Ionization (MALDI)

Types of mass analyzers:

- Quadrupole (Quad, Q)
 - Ion Trap
 - Time-of-Flight (TOF)
- Either source type can work with either analyzer type: “MALDI-TOF,” “ESI-Quad.”
- Analyzers can be combined to create “hybrid” instruments.
ESI-QQQ, MALDI QQ TOF, Q Trap

Summary: acquiring a mass spectrum

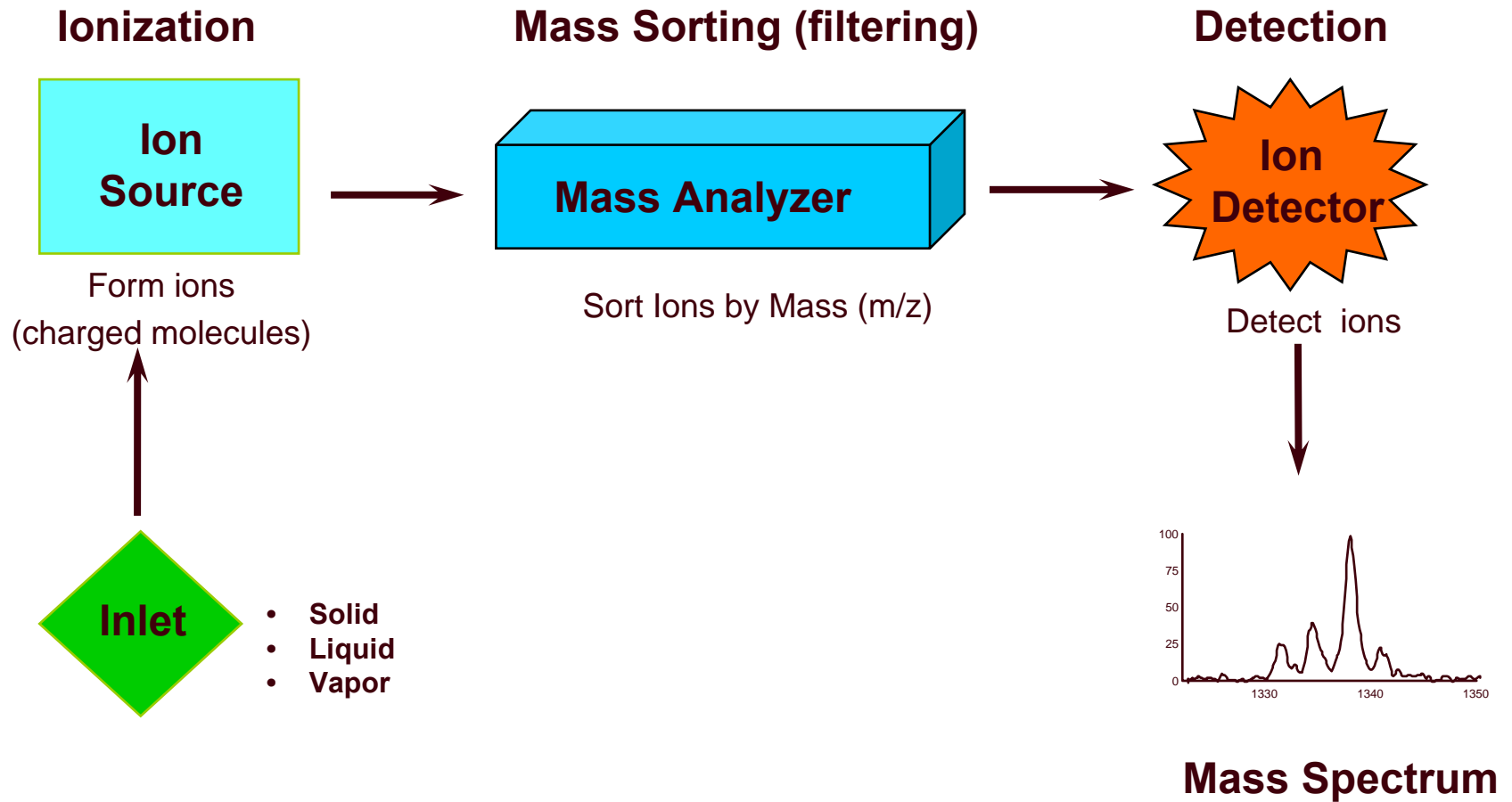

Put it in

- We need ions (+ or -)
- In the gas phase

Your machine

- Tof, Tof / Tof
- Quadrupole, Ion trap
- FT-ICR, Orbitrap (high resolution)
- Hybrids

Tell me the RIGHT answer

- How right is it?

mass resolution and accuracy

How is mass defined?

Assigning numerical value to the intrinsic property of “mass” is based on using carbon-12, ^{12}C , as a reference point.

One unit of mass is defined as a Dalton (Da).

One Dalton is defined as $1/12$ the mass of a single carbon-12 atom.

Thus, one ^{12}C atom has a mass of 12.0000 Da.

Isotopes

+Most elements have more than one stable isotope.

For example, most carbon atoms have a mass of 12 Da, but in nature, 1.1% of C atoms have an extra neutron, making their mass 13 Da.

+Why do we care?

Mass spectrometers can “see” isotope peaks if their resolution is high enough.

If an MS instrument has resolution high enough to resolve these isotopes, better mass accuracy is achieved.

Stable isotopes of most abundant elements of peptides

Element	Mass	Abundance
H	1.0078	99.985%
	2.0141	0.015
C	12.0000	98.89
	13.0034	1.11
N	14.0031	99.64
	15.0001	0.36
O	15.9949	99.76
	16.9991	0.04
	17.9992	0.20

Mass spectrum of peptide with 94 C-atoms (19 amino acid residues)

“Monoisotopic mass”

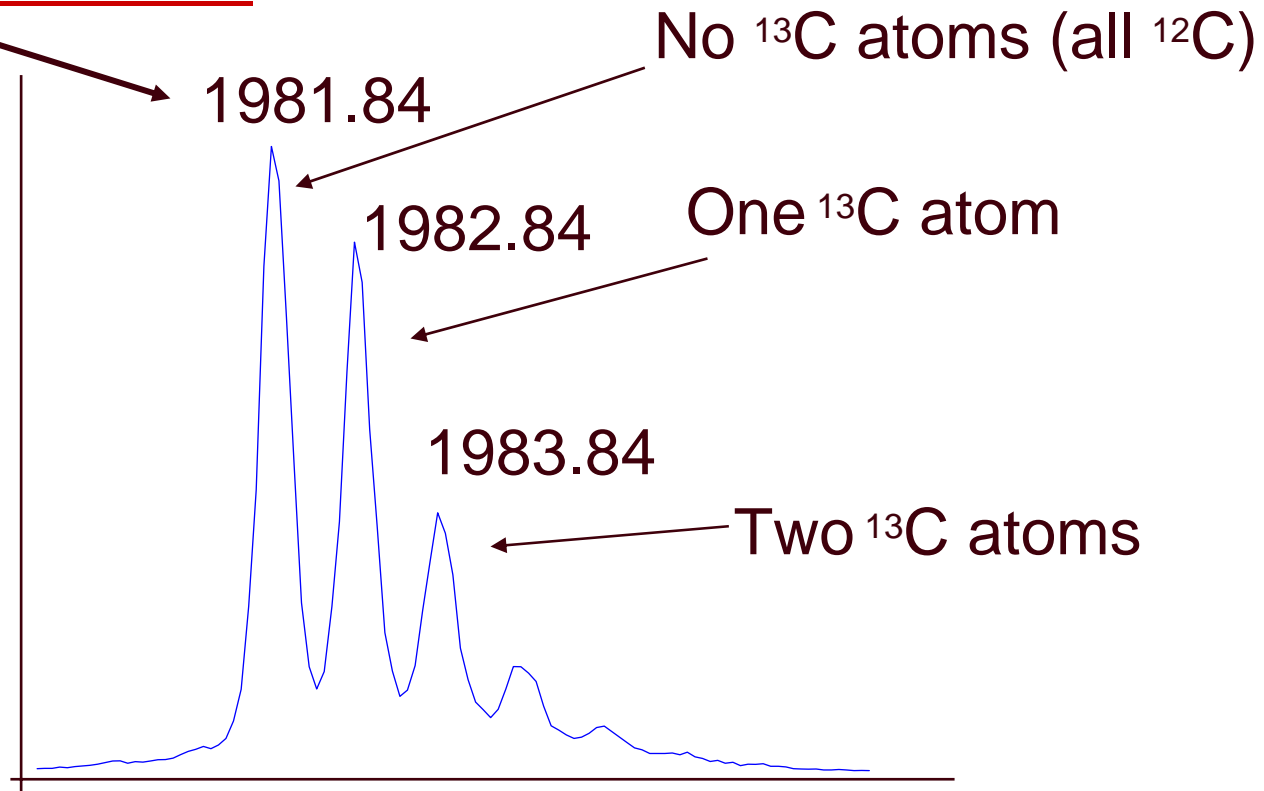

Isotope pattern for a larger peptide (207 C-atoms)

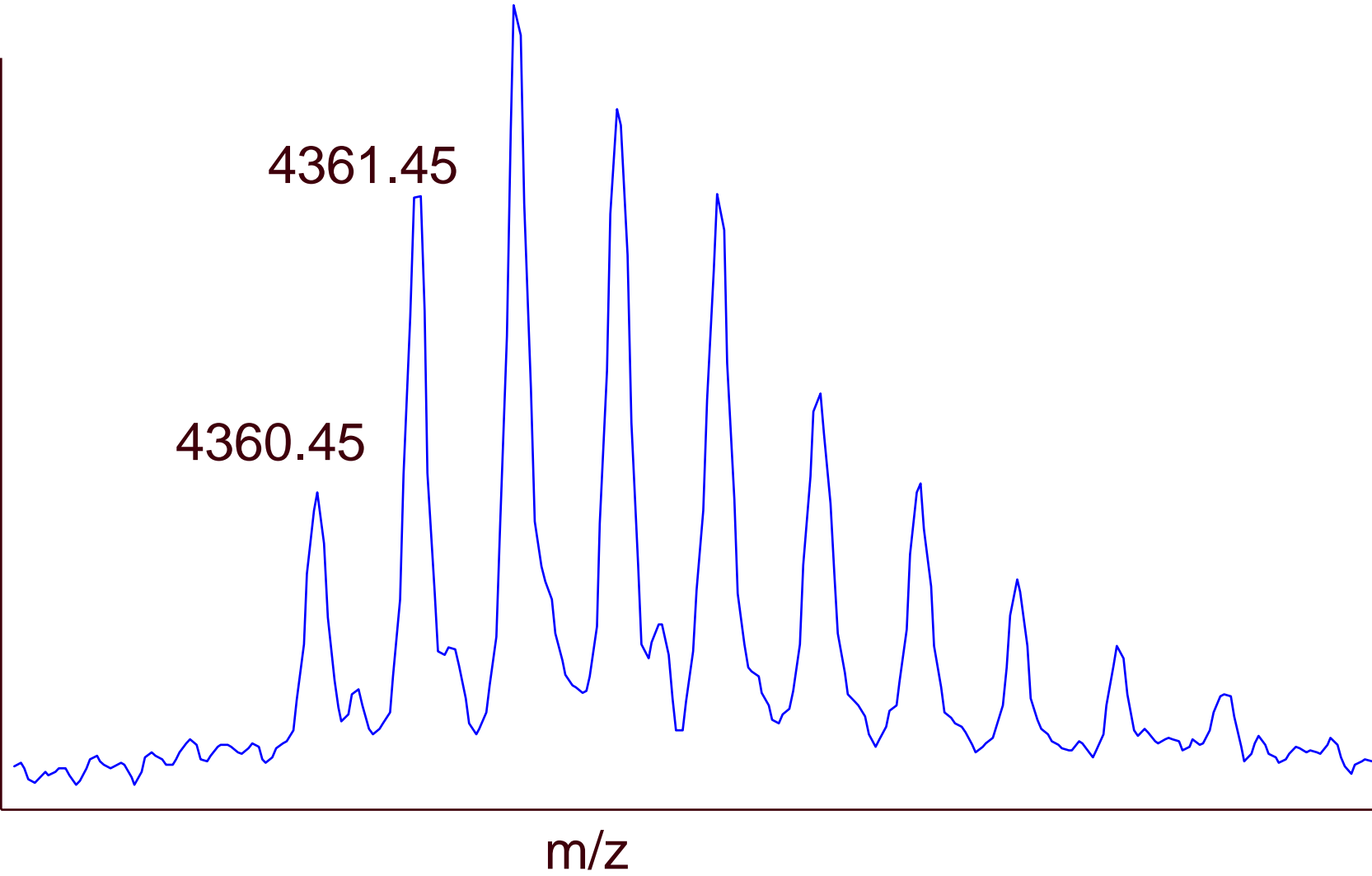

Mass spectrum of insulin

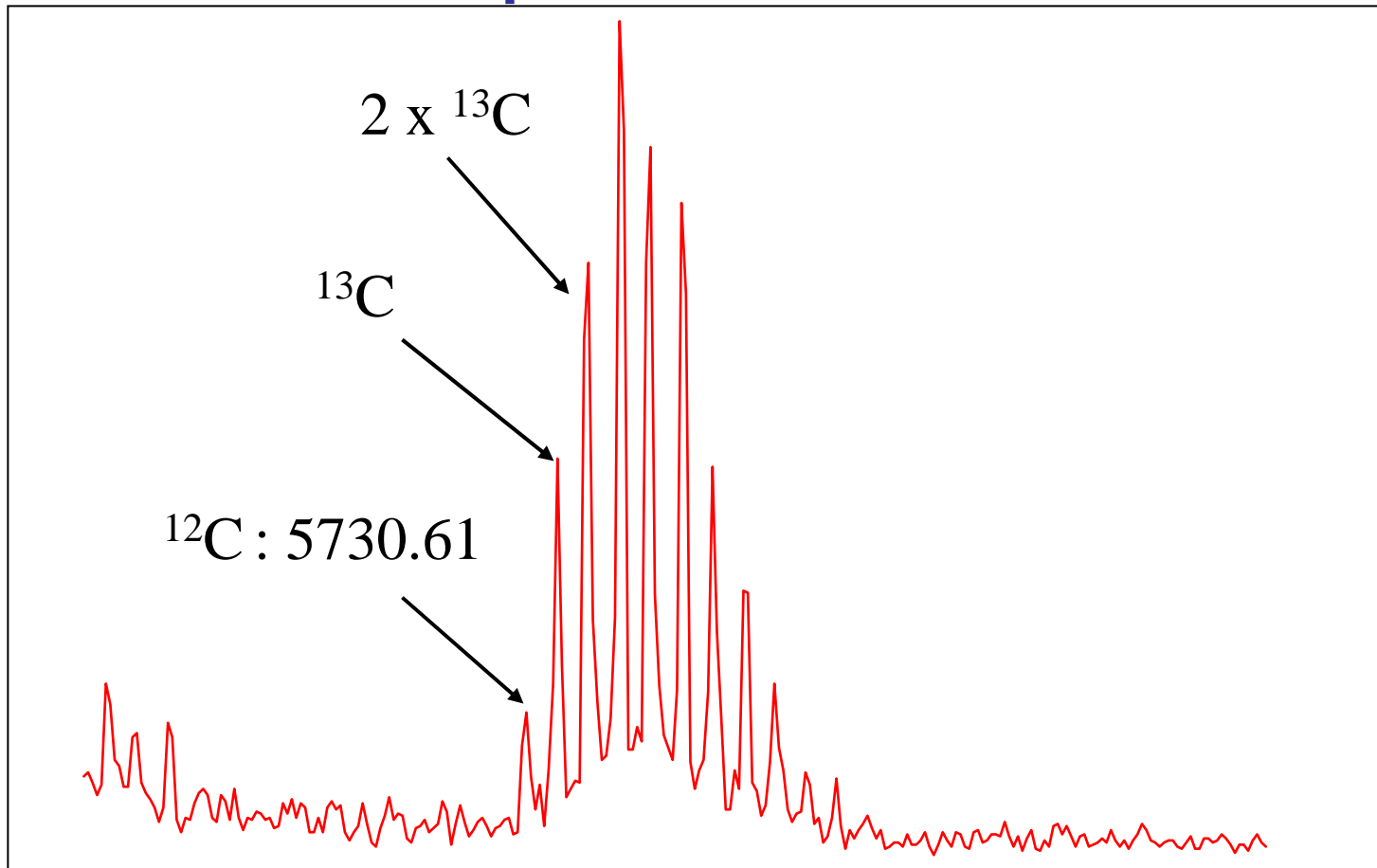

Insulin has 257 C-atoms. Above this mass, the monoisotopic peak is too small to be very useful, and the average mass is usually used.

Monoisotopic mass

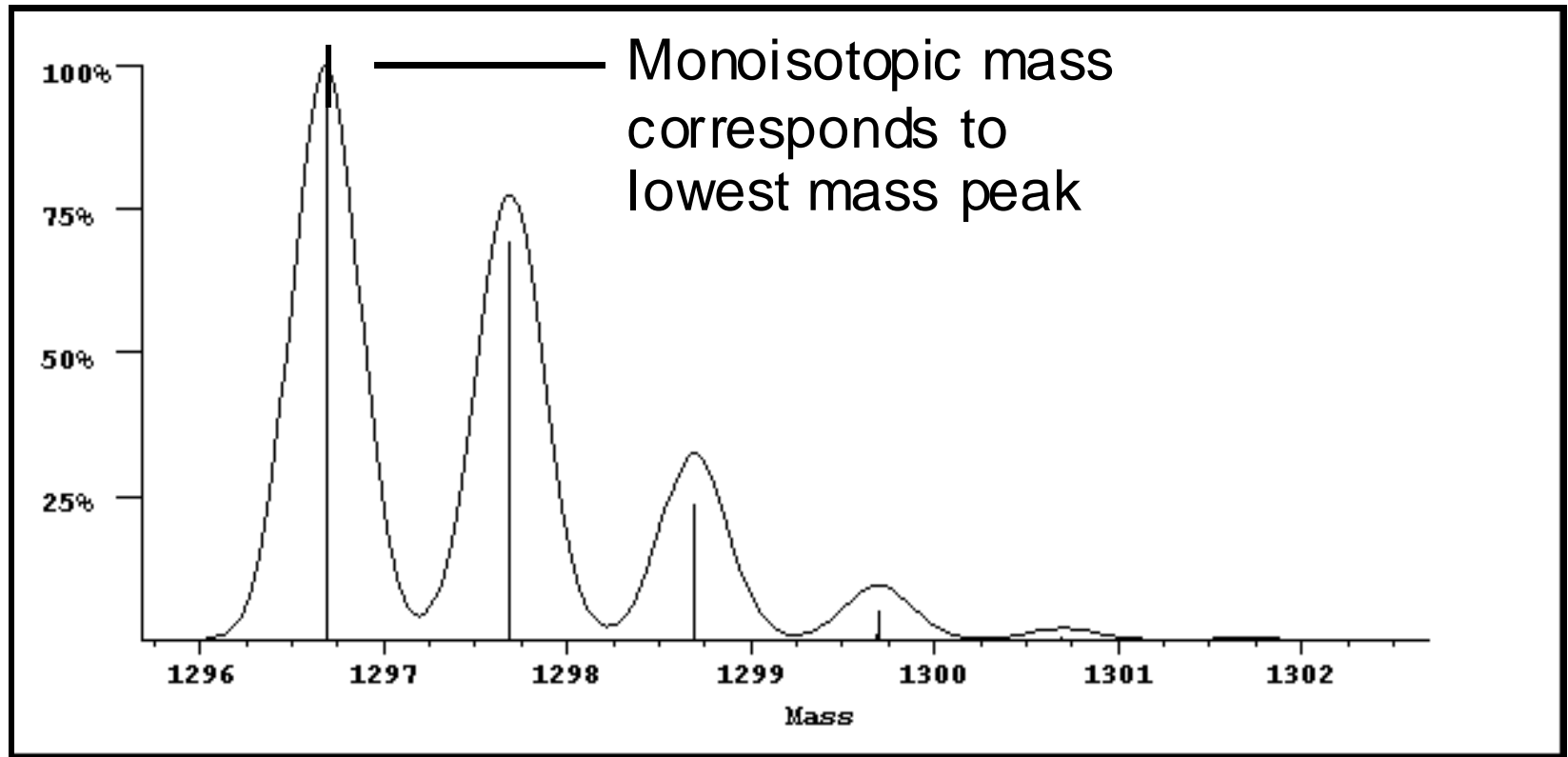

When the isotopes are clearly resolved the **monoisotopic mass** is used as it is the most accurate measurement.

Average mass

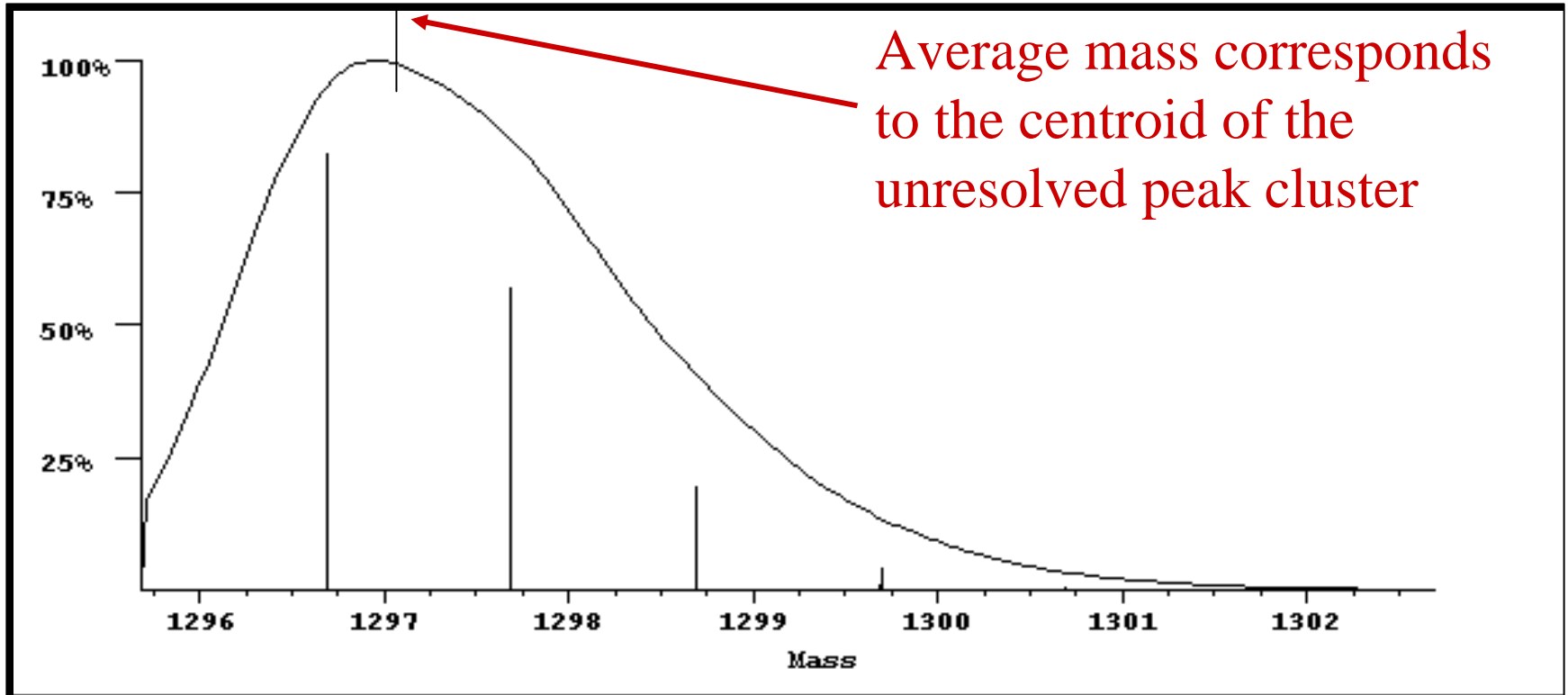

When the isotopes are not resolved, the centroid of the envelope corresponds to the weighted average of all the the isotope peaks in the cluster, which is the same as the average or chemical mass.

What if the resolution is not so good?

At lower resolution, the mass measured is the average mass.

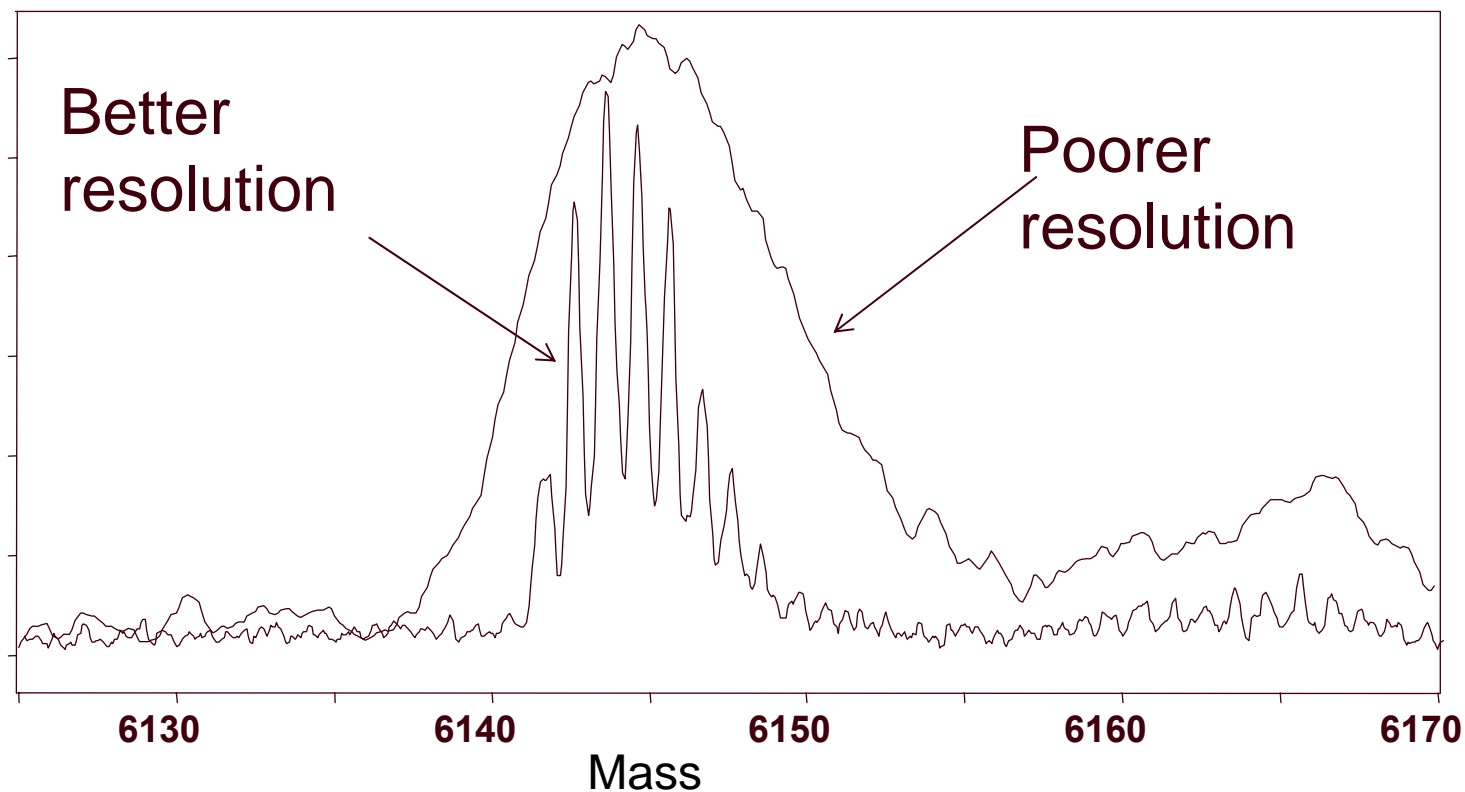

How is mass resolution calculated?

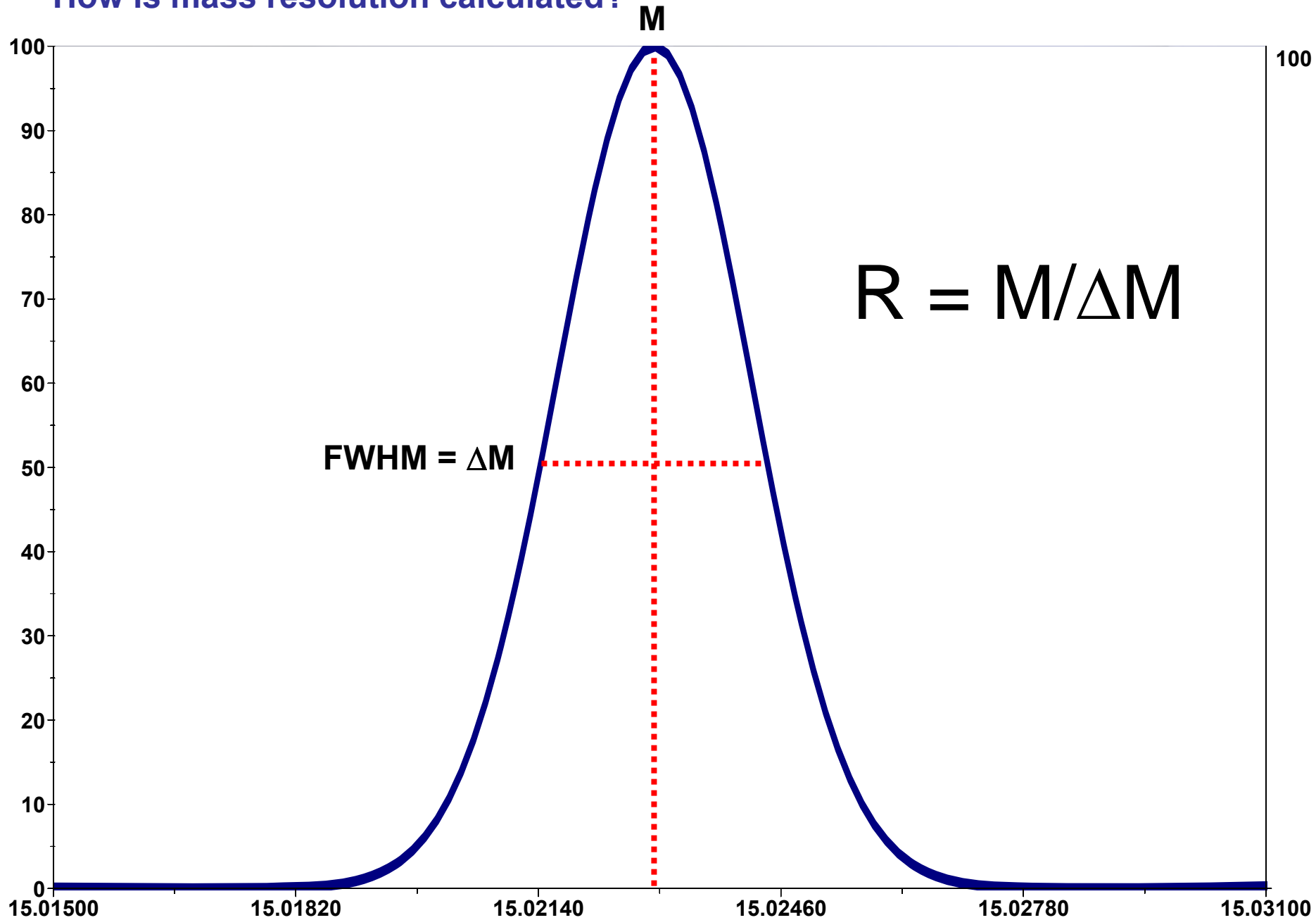

Mass measurement accuracy depends on resolution

High resolution means better mass accuracy

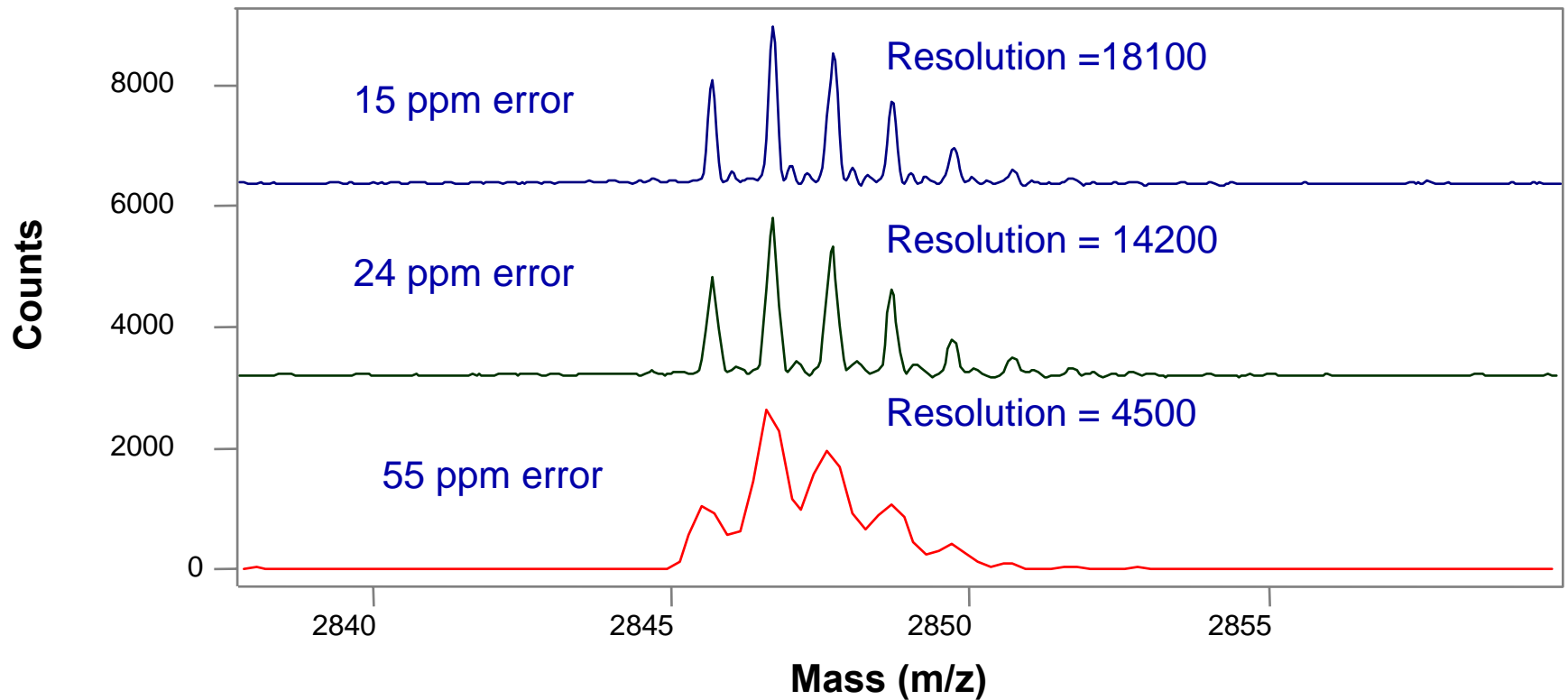

How do we achieve superior mass resolution?

Reflector TOF Mass Analyzer

Delayed Extraction on a MALDI source

Measure frequency

(FT-ICR MS, Orbitrap MS)

Important performance factors

Mass accuracy: How accurate is the mass measurement?

Resolution: How well separated are the peaks from each other?

Sensitivity: How small an amount can be analyzed?

Two peptides - same nominal mass - simulation

Peptide mixture: [Val⁵]-Angiotensin II

Sequence: DRVYVHPF

Formula: C₄₉H₆₉N₁₃O₁₂

Exact mass: [M+2H]²⁺ = 516.76671

Δm (mmu):

Lys-des-Arg⁹-Bradykinin

KRPPGFSPF

C₅₀H₇₃N₁₃O₁₁

[M+2H]²⁺ = 516.78490

18.2 mmu

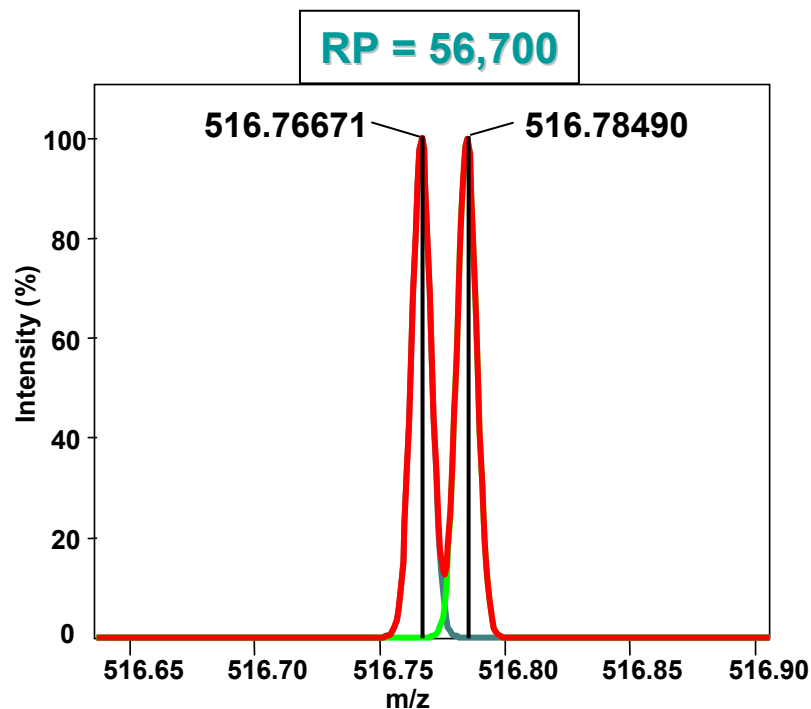
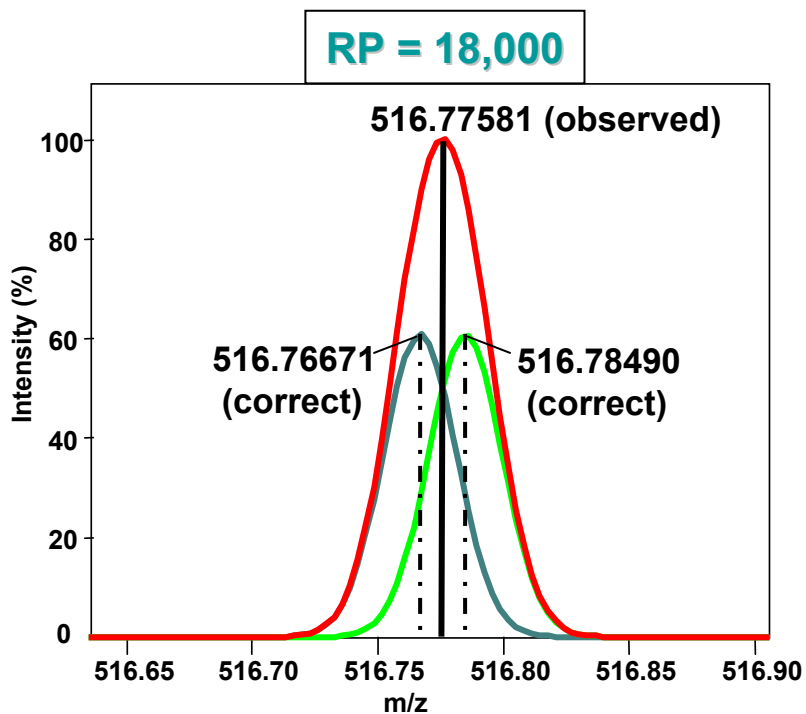

Is Mass Accuracy Important ?

Results for error limit up to 5 ppm

	Theoretical Mass	Delta [ppm]	Delta [mmu]	RDB	Composition
1 ppm (4)	516.76671	0.0	0.0	21.0	C ₄₉ H ₇₁ O ₁₂ N ₁₃
	516.76647	0.5	0.2	15.0	C ₄₉ H ₇₉ O ₁₁ N ₉ S ₂
	516.76638	0.6	0.3	12.0	C ₄₁ H ₇₅ O ₁₄ N ₁₅ S ₁
	516.76705	-0.7	-0.3	11.5	C ₄₃ H ₇₇ O ₁₅ N ₁₂ S ₁
2 ppm (10)	516.76604	1.3	0.7	16.0	C ₄₈ H ₇₅ O ₁₆ N ₉
	516.76738	-1.3	-0.7	20.5	C ₅₁ H ₇₃ O ₁₃ N ₁₀
	516.76604	1.3	0.7	21.5	C ₄₇ H ₆₉ O ₁₁ N ₁₆
	516.76580	1.8	0.9	15.5	C ₄₇ H ₇₇ O ₁₀ N ₁₂ S ₂
	516.76772	-2.0	-1.0	16.5	C ₄₄ H ₇₃ O ₁₁ N ₁₆ S ₁
	516.76773	-2.0	-1.0	11.0	C ₄₅ H ₇₉ O ₁₆ N ₉ S ₁
5 ppm (23)	516.76805	-2.6	-1.3	25.5	C ₅₂ H ₆₉ O ₉ N ₁₄
	516.76537	2.6	1.3	16.5	C ₄₆ H ₇₃ O ₁₅ N ₁₂
	516.76807	-2.6	-1.4	7.0	C ₃₈ H ₇₉ O ₁₄ N ₁₅ S ₂
	516.76513	3.0	1.6	10.5	C ₄₆ H ₈₁ O ₁₄ N ₈ S ₂
	516.76513	3.1	1.6	16.0	C ₄₅ H ₇₅ O ₉ N ₁₅ S ₂
	516.76839	-3.3	-1.7	16.0	C ₄₆ H ₇₅ O ₁₂ N ₁₃ S ₁
	516.76479	3.7	1.9	20.0	C ₅₂ H ₇₅ O ₁₁ N ₉ S ₁
	516.76872	-3.9	-2.0	25.0	C ₅₄ H ₇₁ O ₁₀ N ₁₁
	516.76470	3.9	2.0	17.0	C ₄₄ H ₇₁ O ₁₄ N ₁₅
	516.76874	-3.9	-2.0	6.5	C ₄₀ H ₈₁ O ₁₅ N ₁₂ S ₂
	516.76446	4.3	2.2	11.0	C ₄₄ H ₇₉ O ₁₃ N ₁₁ S ₂
	516.76897	-4.4	-2.3	12.5	C ₄₀ H ₇₃ O ₁₆ N ₁₆
	516.76907	-4.6	-2.4	15.5	C ₄₈ H ₇₇ O ₁₃ N ₁₀ S ₁

Mass Resolution = $m / \Delta m$ 50%

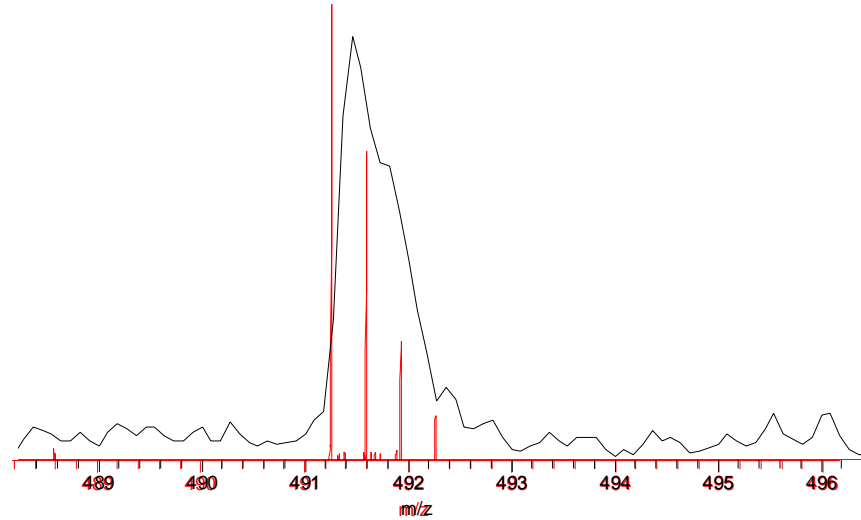

**RP = 491.2594 / 0.0055 amu
= 89,319**

**RP = 491.45 / 0.69 amu
= 712**

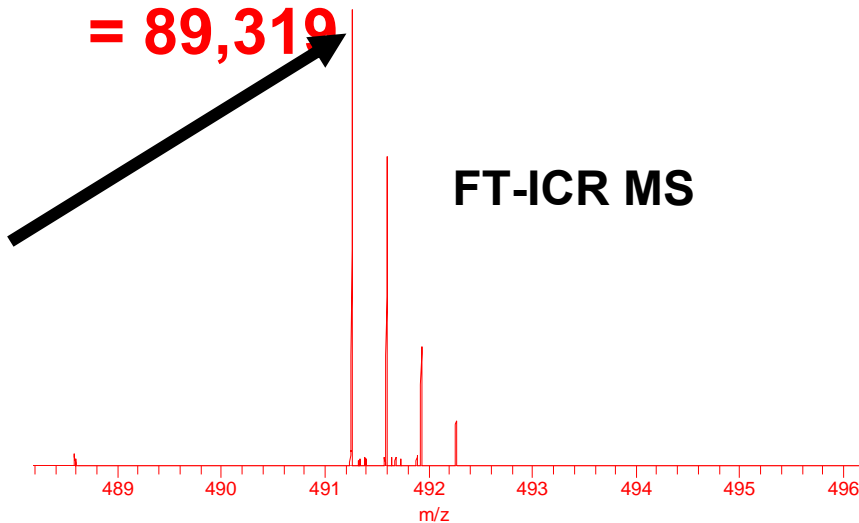

FT-ICR MS

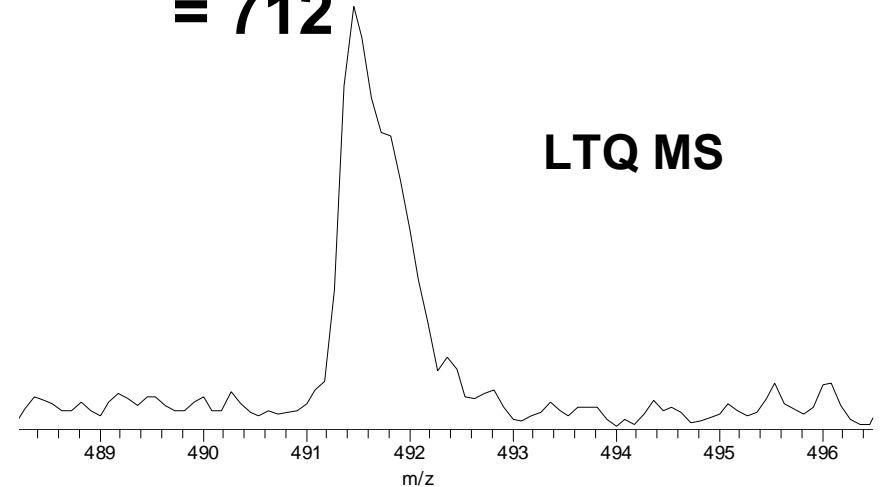

LTQ MS

Objectives of the Lecture

1. Make ions

ESI, MALDI

2. Separate/Analyze/Detect ions

Tof, ion trap, quadrupole,

FT-ICR, Orbitrap

Electron multipliers

3. What is mass resolution and mass accuracy?

Slide Acknowledgements

Thermo Electron (Fisher)

Bruker

ABI

Sandler Mass Spectrometry Group

David Agard group

<http://www.msg.ucsf.edu/agard/>

(Univ. of Calif Sanfrancisco)