

G2060–Site Development – UniFormat to MasterFormat Conversion Chart

G2060 Site Development	MasterFormat No.	Title
G2060.25 Site Furnishings	12 93 13	Bicycle Racks

G.2060- Site Development

12 93 13 BICYCLE RACKS

A. Purpose

1. This Section describes the guidelines necessary for providing bike racks at the University. The responsibility of the architect/engineer/contractor is to apply the principles of this section such that the University may achieve a level of quality and consistency in the design, operation, and construction of their facilities.

B. Requirements

See diagrams for bike rack component and typical bike rack layout.

1. Components:

- a. Bike rack to be powder coated, RAL 6005 Moss Green
- b. "BIKE UAB" font is Quicksand bold.
- c. "BIKE UAB" plates are not required on interior bike racks with installations of four or more.

2. Mounting: To be surface mounted and anchored into concrete using expansion bolts and security nuts.

3. Location: Bike racks shall be located within a one hundred (100) foot diameter of the primary building entrance(s).

4. Quantity:

- a. UAB bike rack accommodates two bike spaces
- b. Required:
 - i. Residence hall: 1 space per 20 beds
 - ii. Student activity center / classroom building: 1 per 4500 sf (gross)
 - iii. Support service / office: 1 per 5000 sf (gross)

C. Products

1. UAB Bike rack by Foster Phillips (205.291-8353, foster@localbikeco.com) or approved equal product.

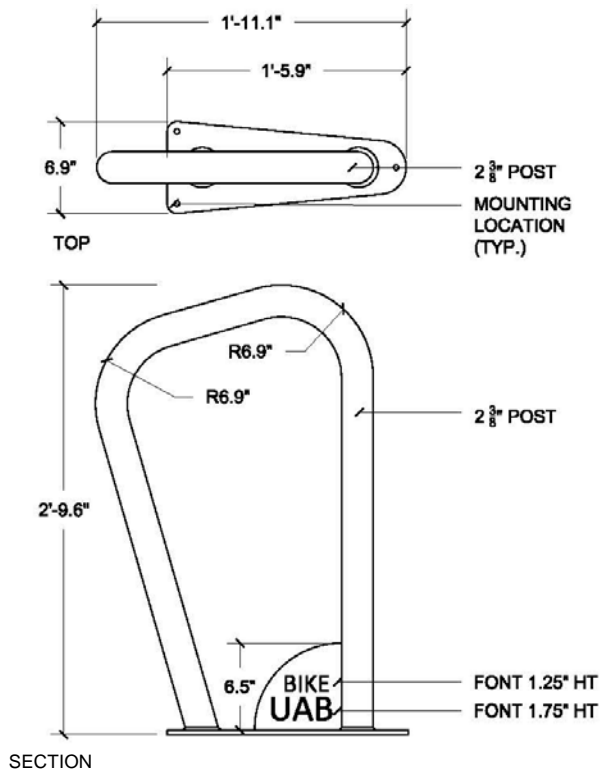

EXHIBIT – BIKE RACK

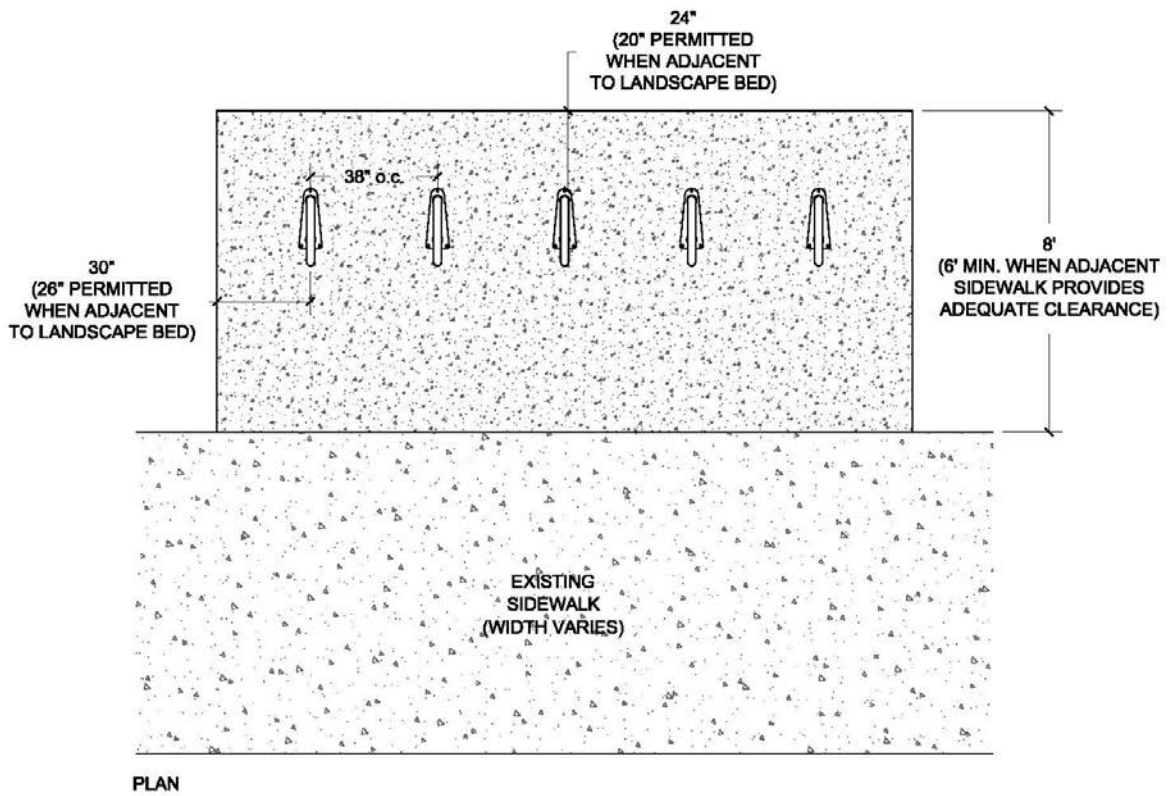

EXHIBIT - TYPICAL PLACEMENT

Revision Request Form – Site Furnishings Standards

Date: _____

Requestor: _____

Department/Consultant: _____

Project Number & Name: _____

EXISTING SITE FURNISHINGS STANDARD

Section Number & Name: _____

Section Revision Number: _____ Section Paragraph: _____

(ENTER CURENT SECTION LANGUAGE BELOW)

REQUESTED REVISION REQUEST

(ENTER REVISION SECTION LANGUAGE BELOW)- **Identify if request will be permanent to standards or for the referenced project.**

JUSTIFICATION FOR REVISION

FOR UNIVERSITY OF ALABAMA AT BIRMINGHAM USE ONLY

UAB Staff Requestor: _____

Authorized UAB Approval Personnel: _____ Date: _____

Status: _____ Rejected _____ Accepted

_____ Revise and Resubmit (see attachment)